

The VLT Interferometer Takes Shape

The True History of VLTI

Oskar von der Lühe

Kiepenheuer-Institut für Sonnenphysik

Freiburg, Germany

The VLT about 1985

Presented by Daniel Enard

ESO-NOAO Conference on Very Large Telescopes, Garching 1985



VLT as a Linear, Redundant Array

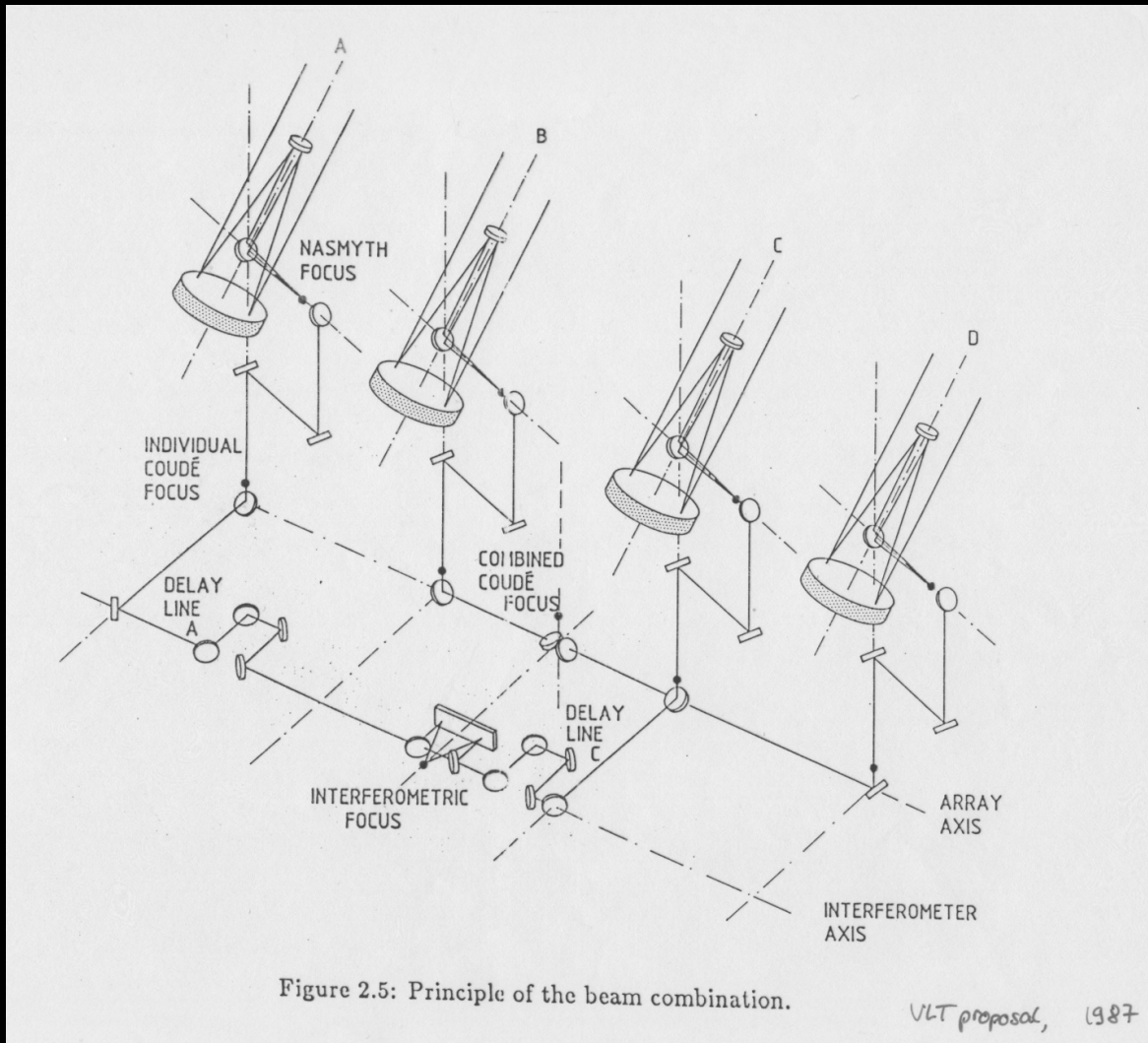

Fritz Merkle

Jacques Maurice Beckers

Jacques was head of the interferometry group from 1988 to 1991.

He developed many of the fundamental concepts that VLTI is based upon today.



Multiple Mirror Telescope, Mt. Hopkins

- Coherent combination of two and six separate primary mirrors
- Extended fields of view if entrance and exit pupil are proportionally scaled („homothetic mapping“)

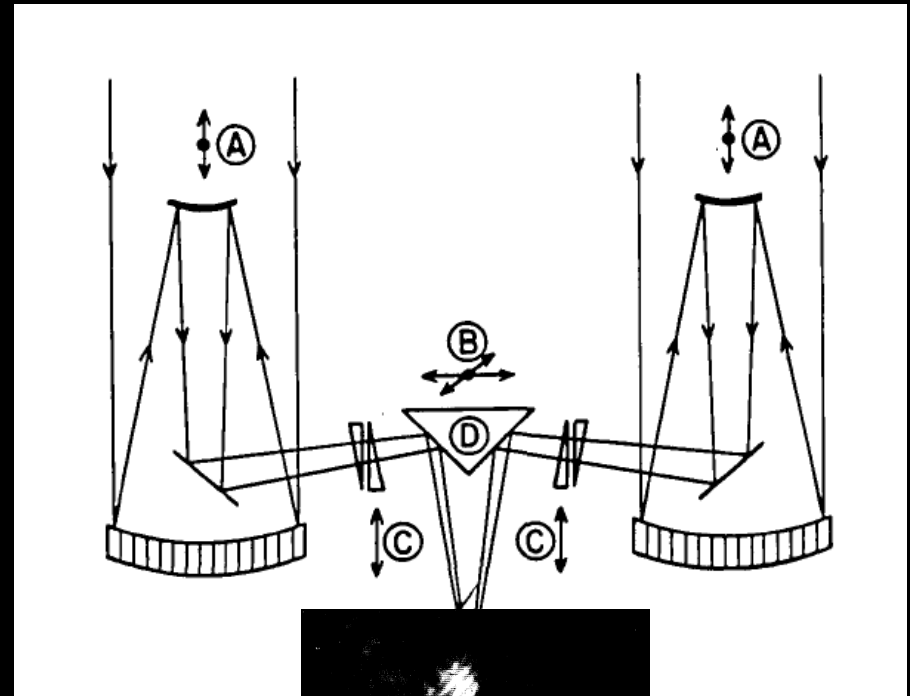

Main Principles for Interferometry

- Maintain the Polarization reference of frame
 - Make the optical design of all array elements equal
 - As many right angles as possible
- Maintain the shortest optical path to the point of interference
 - Put UTs on legs of a right-angles triangle
- Have non-linear, non-redundant baselines

Responsibilities of the VLTI Group in the late 1980s and early 1990s

- Site layout
- Auxiliary Telescopes
- Delay lines
- Transfer optics
- UT Coude relay optics
- Interferometry instruments
- Input to the rest of VLT
- Liaison to community

This was a one man
show in 1988, a two
man show in 1989,
and a three man
show from 1990 to
1994

...and it turned out to be the right size. The rest of the VLT team was just wonderfully helpful.

Early VLTi Concept

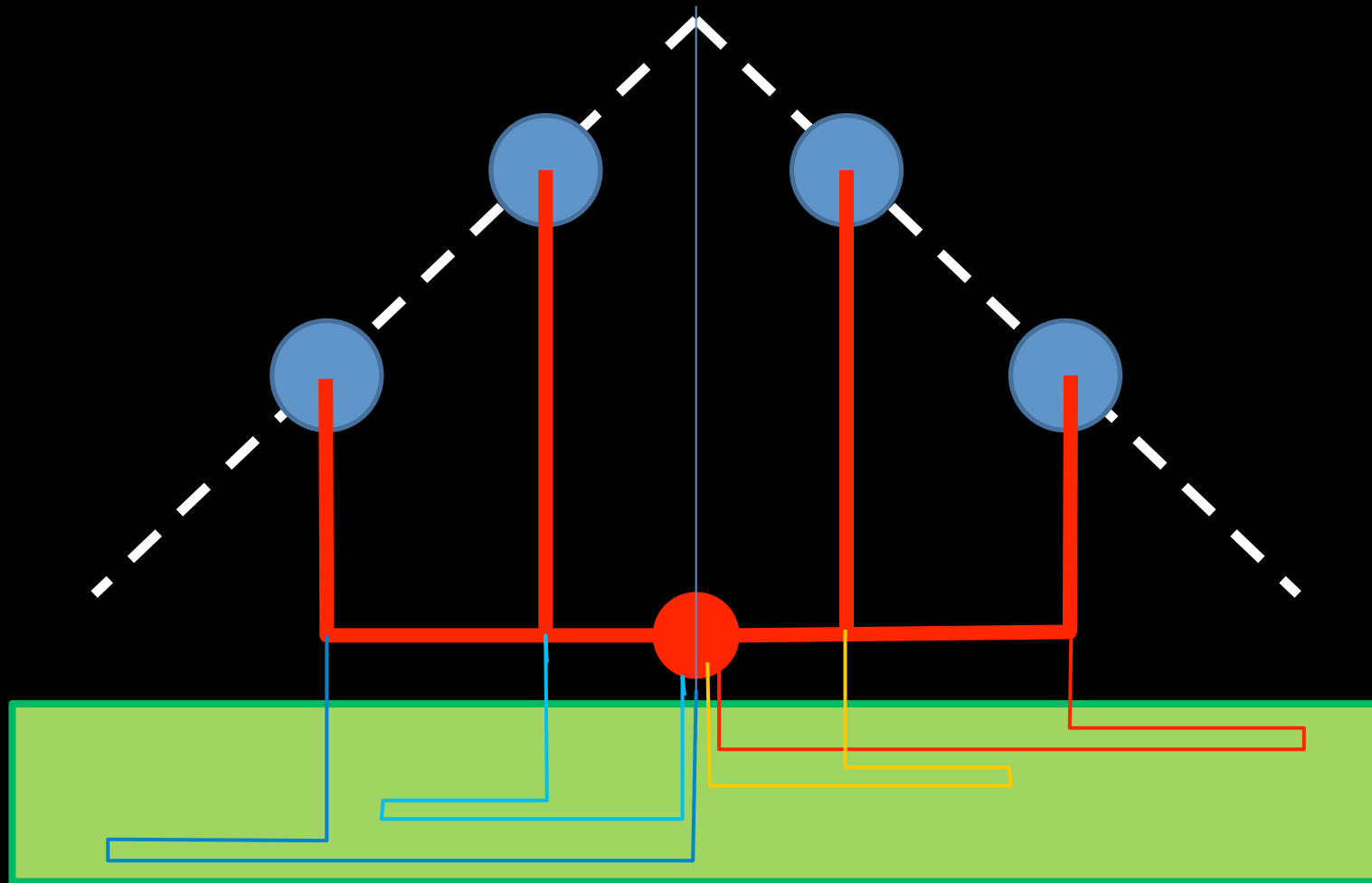

VLT / VLTI Layout at Paranal in the early 1990s

- Central Laboratory with incoherent and coherent beam combining stations
- Delay Line Tunnel
- AT Tracks co-aligned with Uts
- Separate control room
- Much bigger interferometry lab

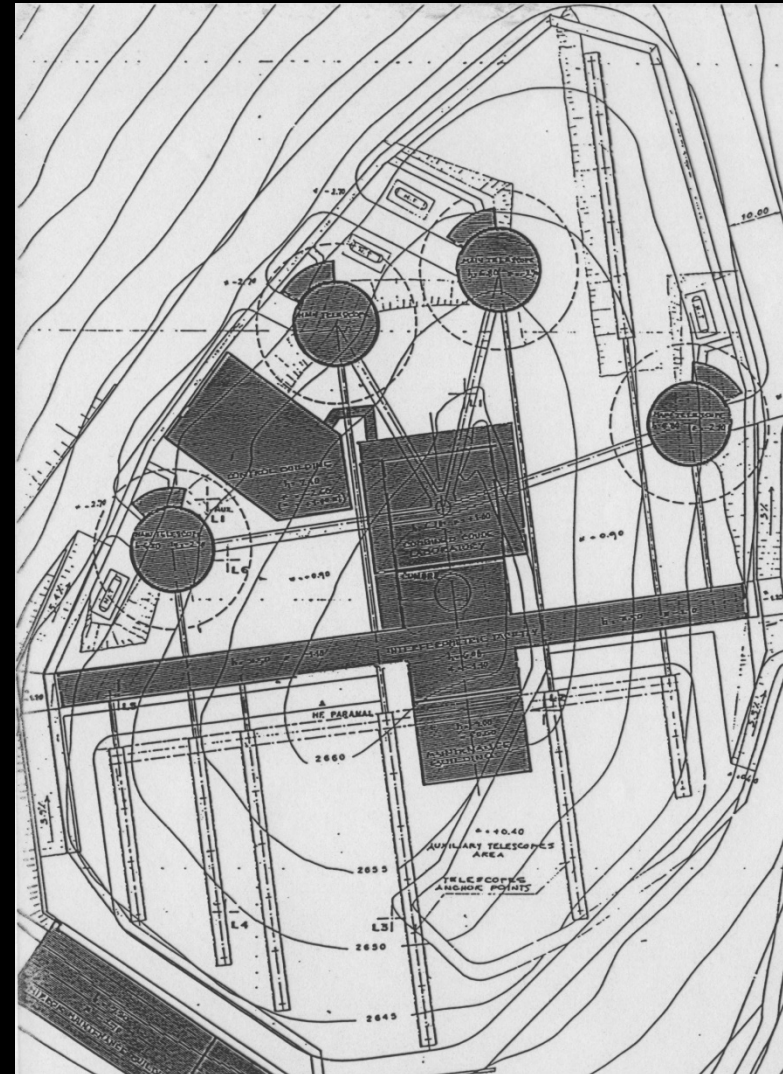

The Alignment Crisis

- Linear layout?
 - Redundancy has advantages wrt. photon statistics
- 2D Layout?
 - Non-redundant baselines provide better UV coverage

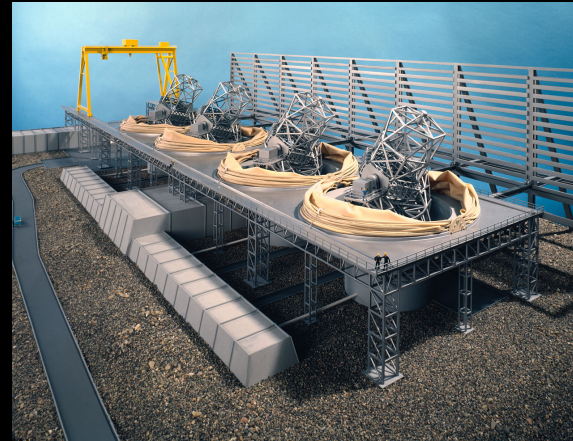

VLT Layout Tiger Team

- Members
 - Robert Braun
 - Tim Cornwell
 - Shri Kulkarni
 - Jean-Marie Mariotti
 - Jan Noordam
 - Farrokh Vakili
 - Oskar v. d. Lühe (chair)
 - Gerd Weigelt
 - did I miss anybody?
- Main conclusion was that a non-redundant configuration would be the best configuration for an optical interferometer with a limited number of baselines

Shaping the Mountain

- The configuration of **Unit Telescopes** was based on environmental considerations
 - „UTs shall not obscure each other from the wind“
 - „UTs shall be located on solid bed rock“
- The configuration of Auxiliary Telescope stations was entirely left to the VLT Group

VLT Site Configuration, early 1992

- Three UTs at NW edge
 - Main wind direction from NW
 - UT4 positioned just outside the wake of UT3
 - All telescopes are on an 8x8m grid
- AT configuration to optimize the interferometry return

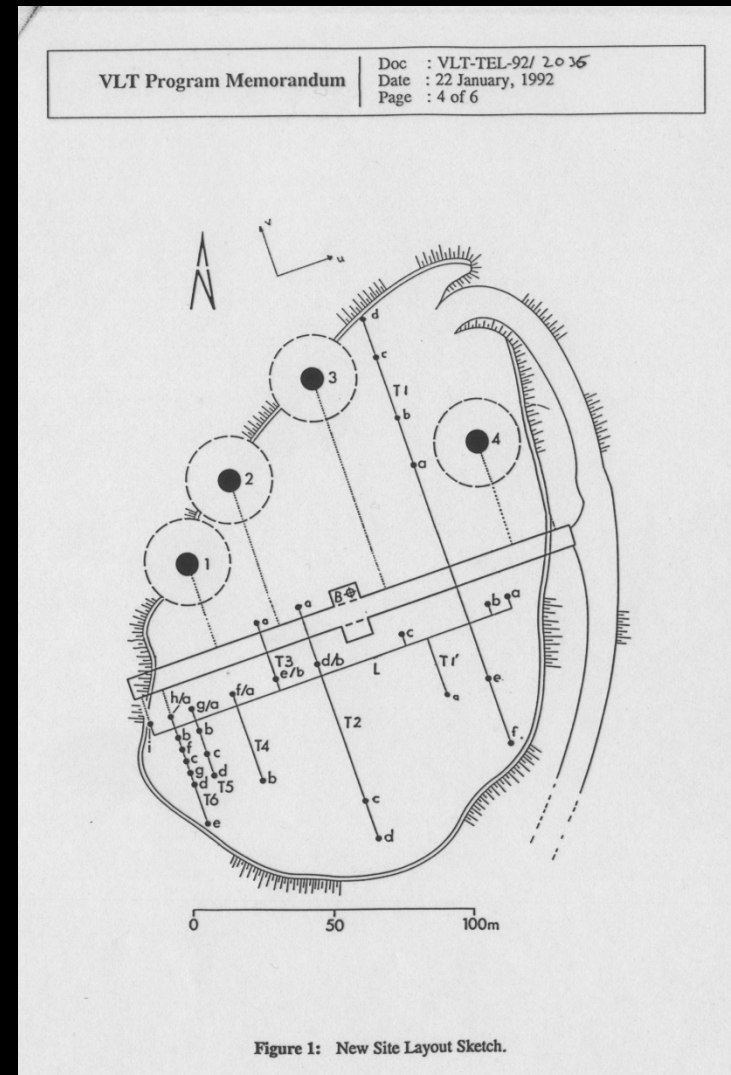

The Layout Crisis

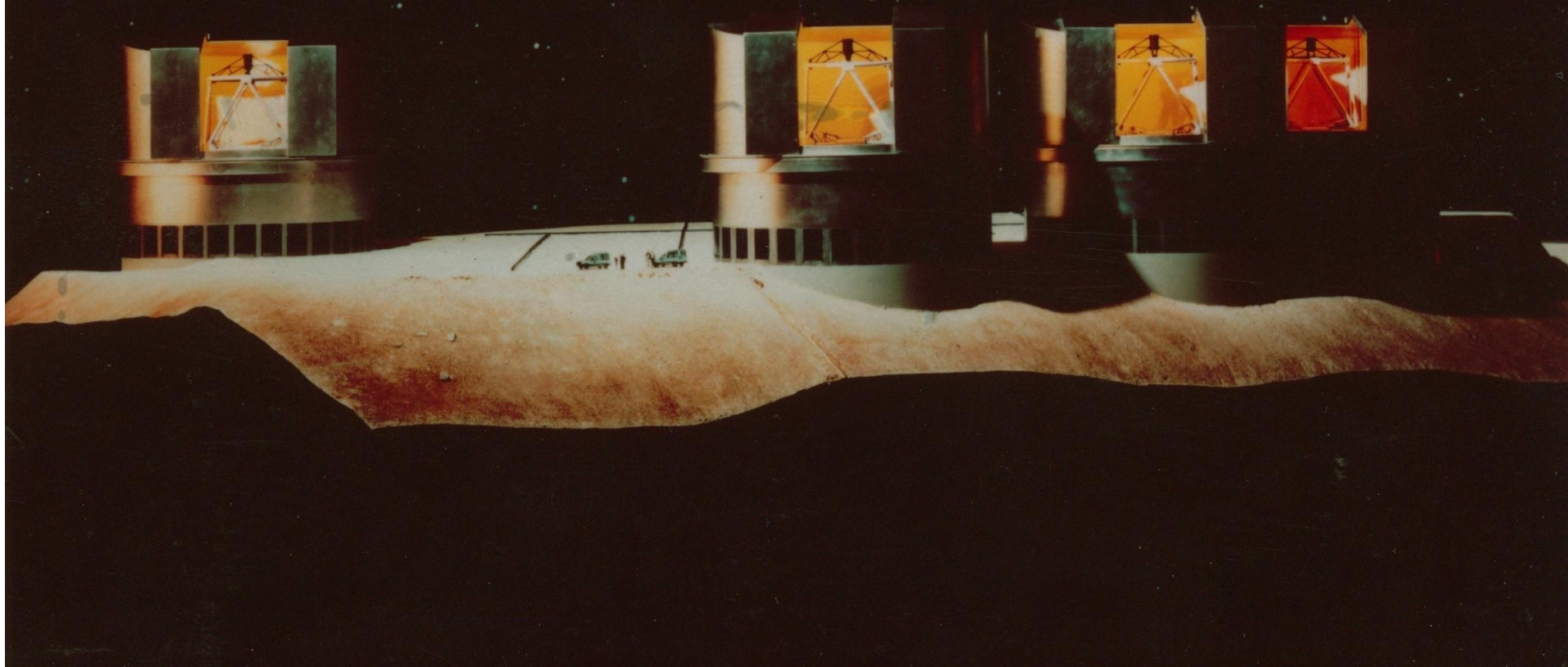

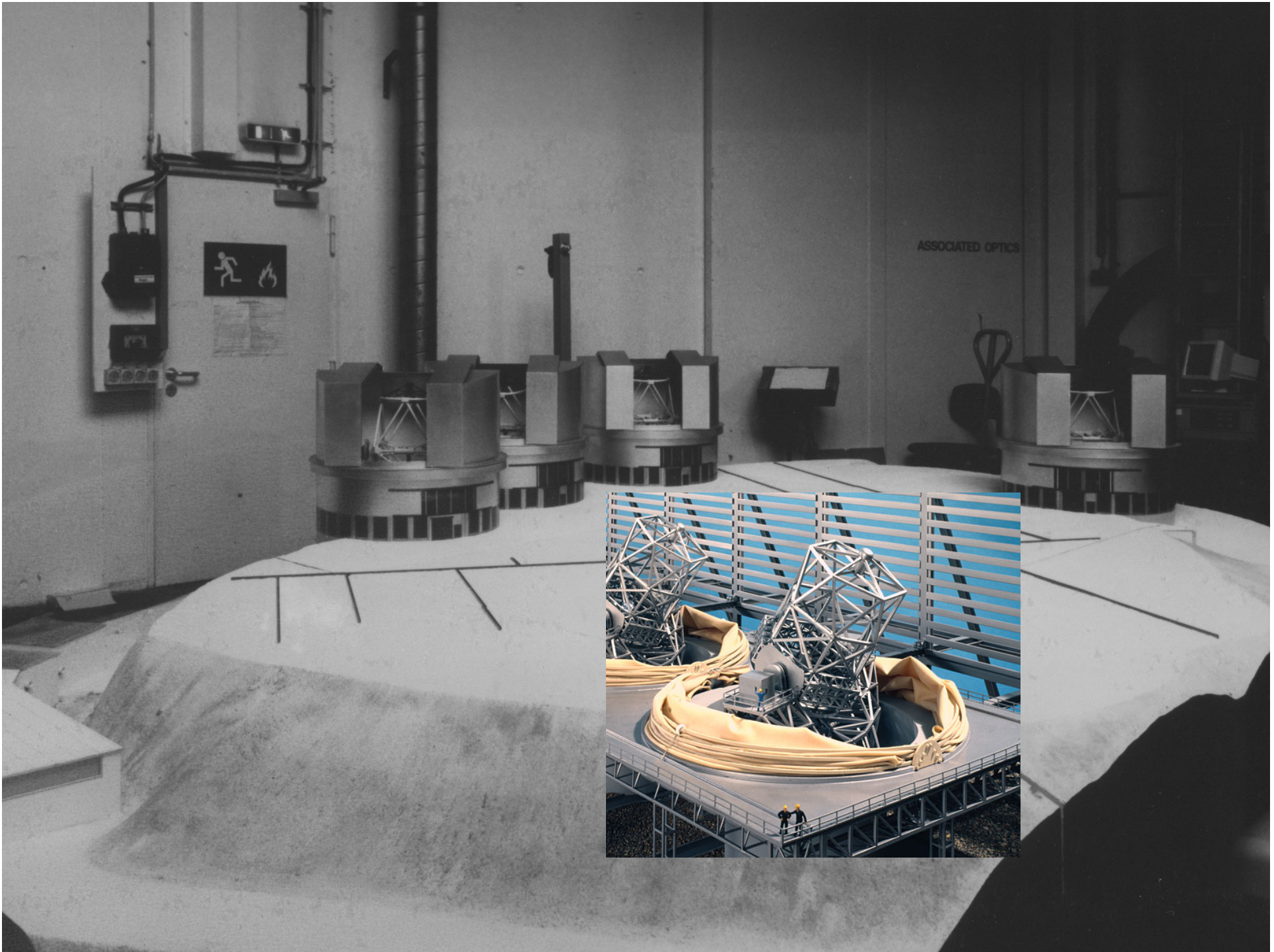

Panic ...

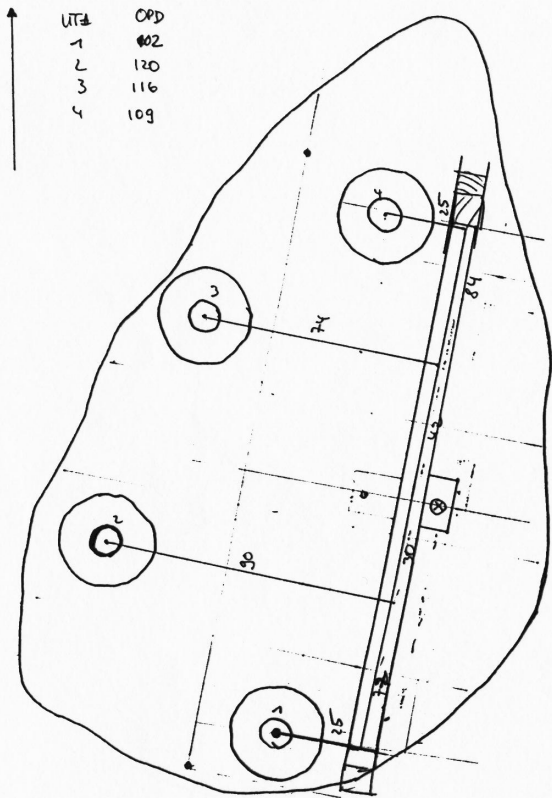

Layout 01

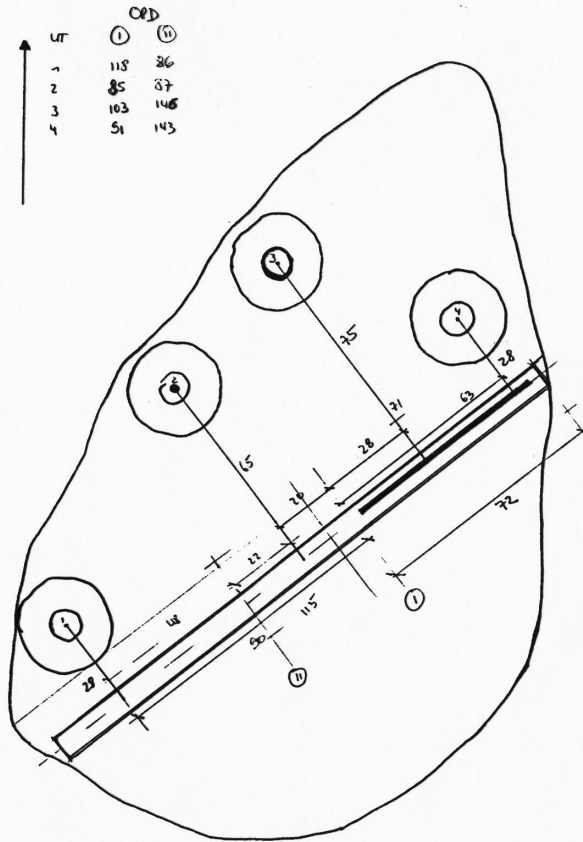

Layout 02

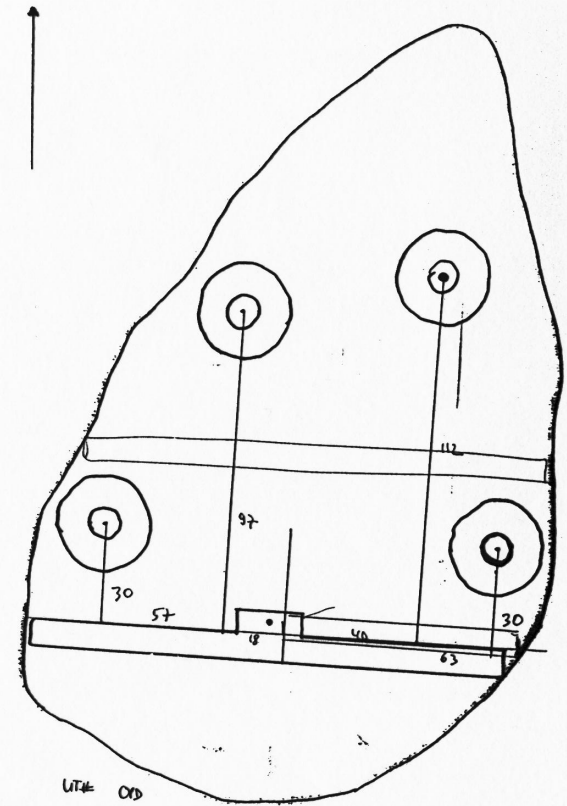

Layout 03

... and
desperation!

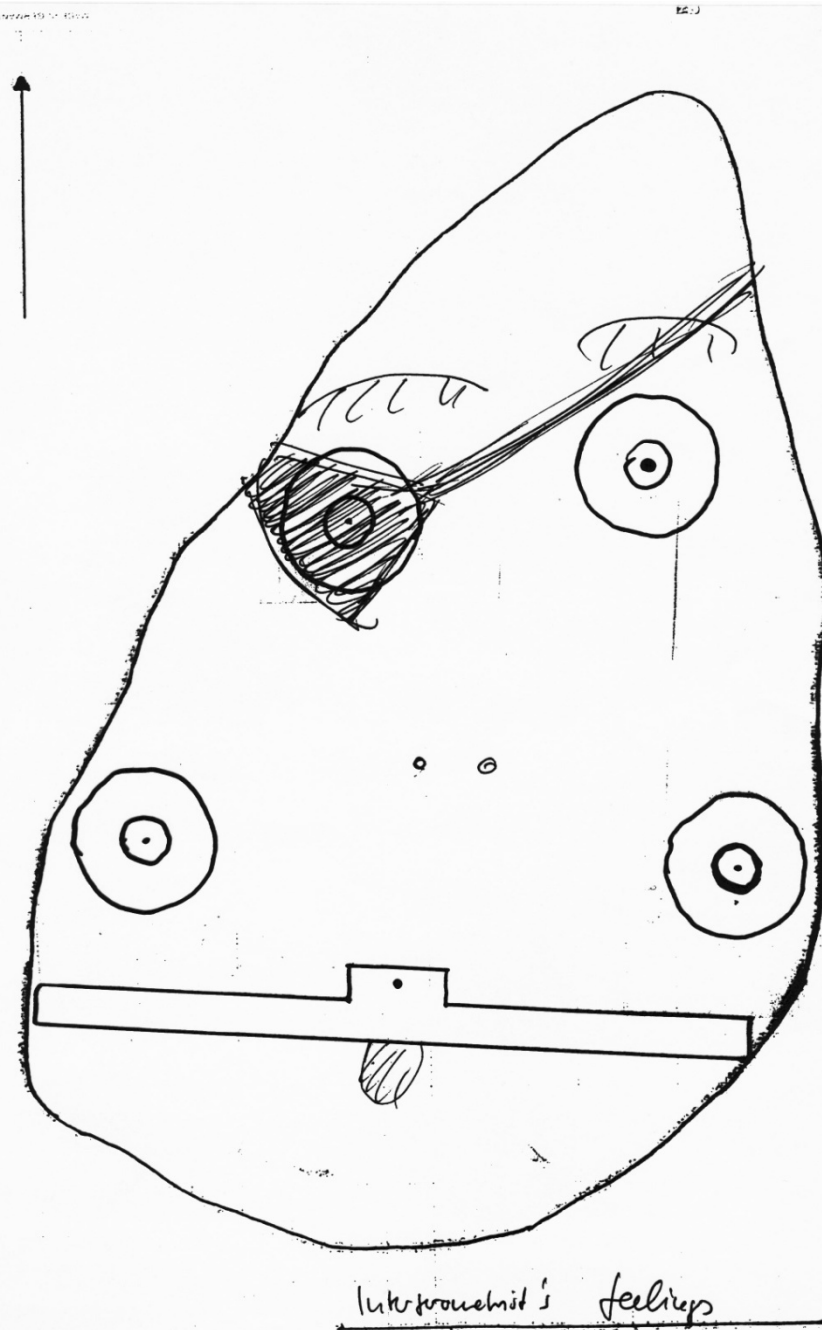

But common sense prevails.

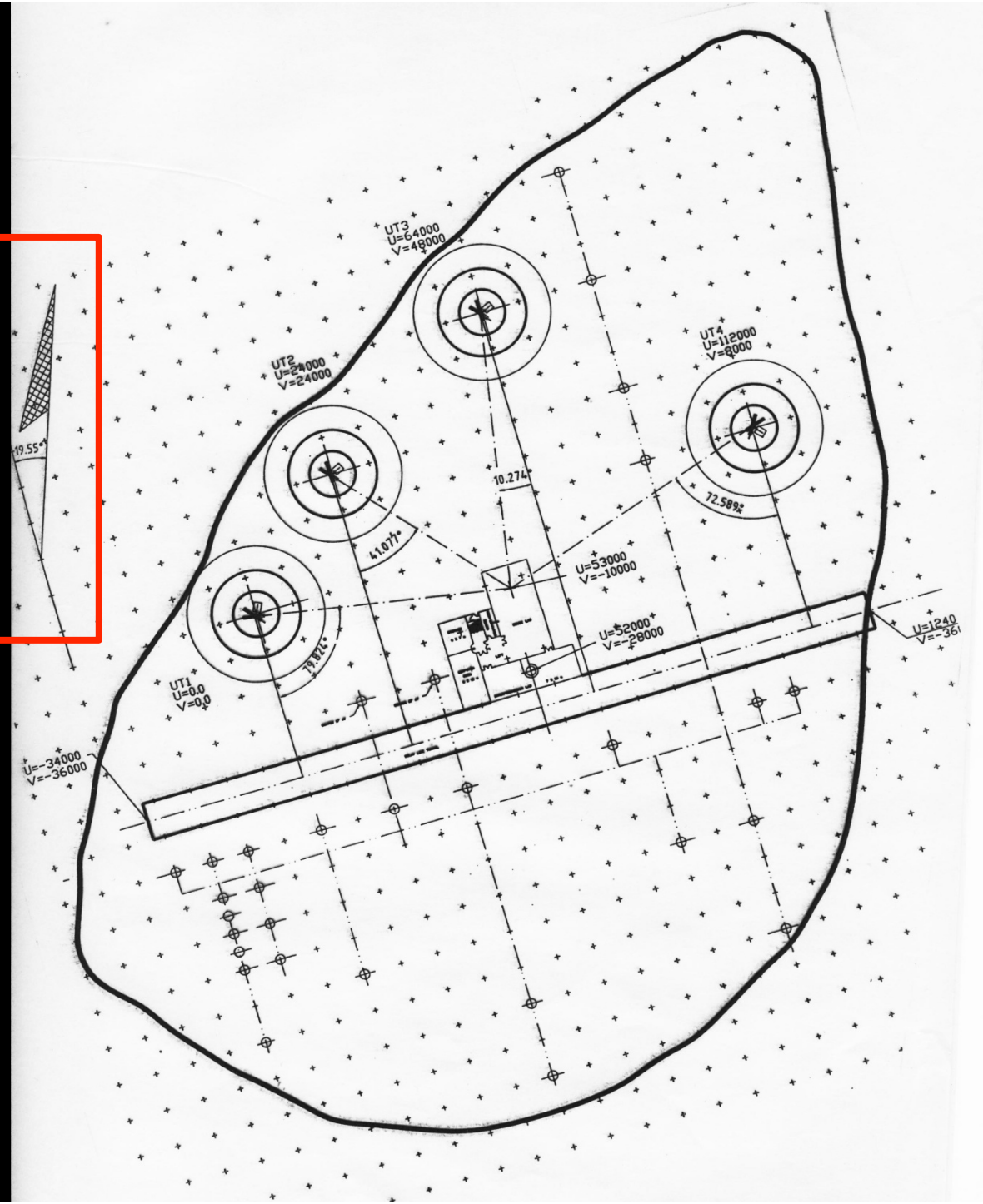
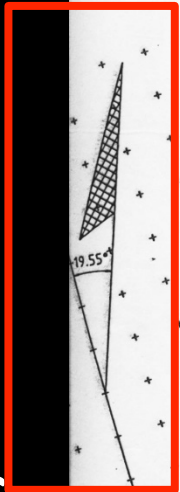

Why 19.55 degrees?

- This is not clear. The layout was designed by us with a 20° angle between the EW direction and the horizontal direction of the 8m grid – on a piece of paper. The odd angle must have entered when somebody took it from that sketch.
- Somebody took interferometry **that seriously!**

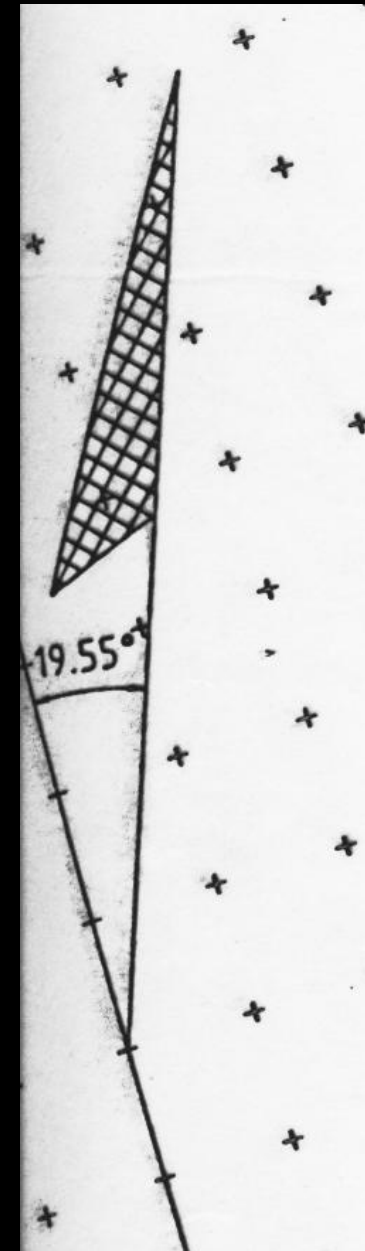

Why are the AT Stations where they are?

Hybrid Mode:

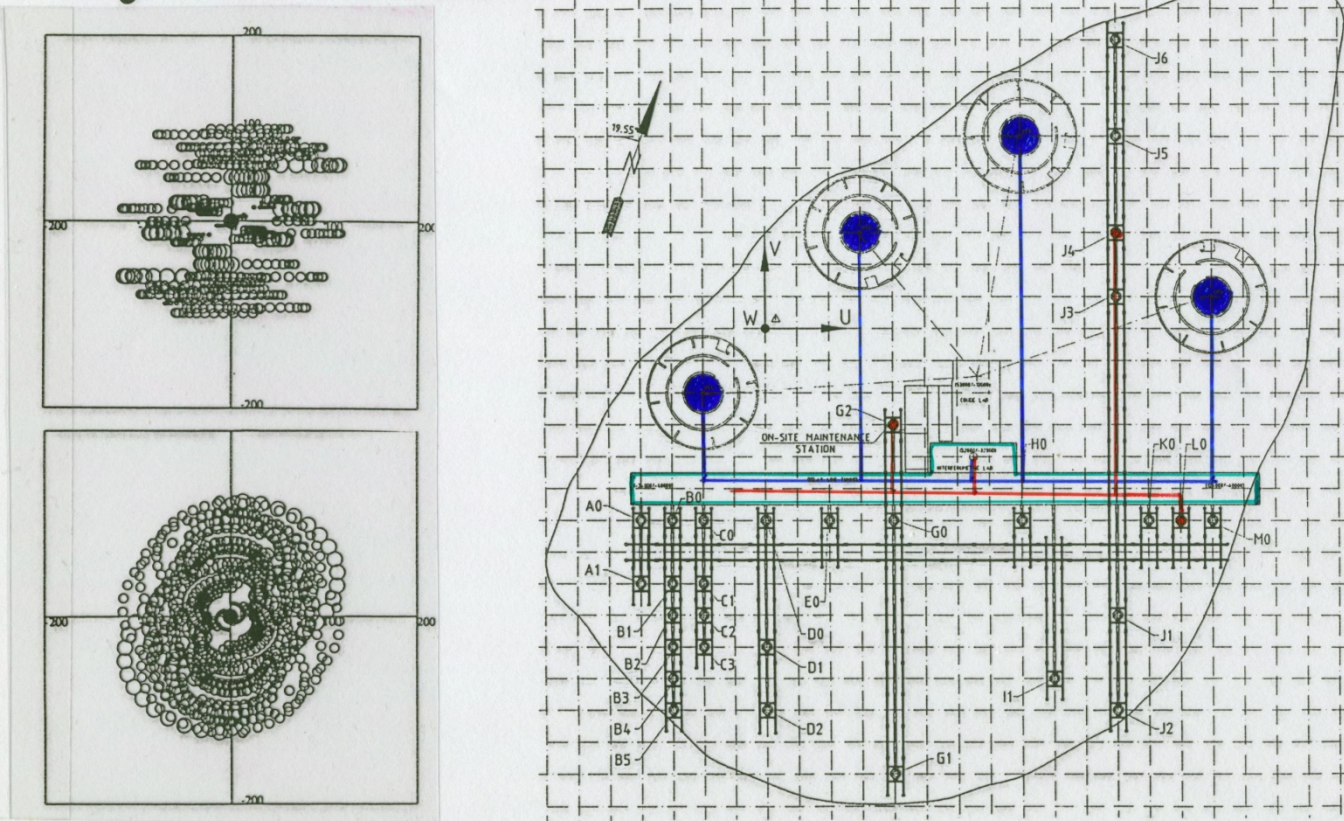

Flexibility of Sub-Array

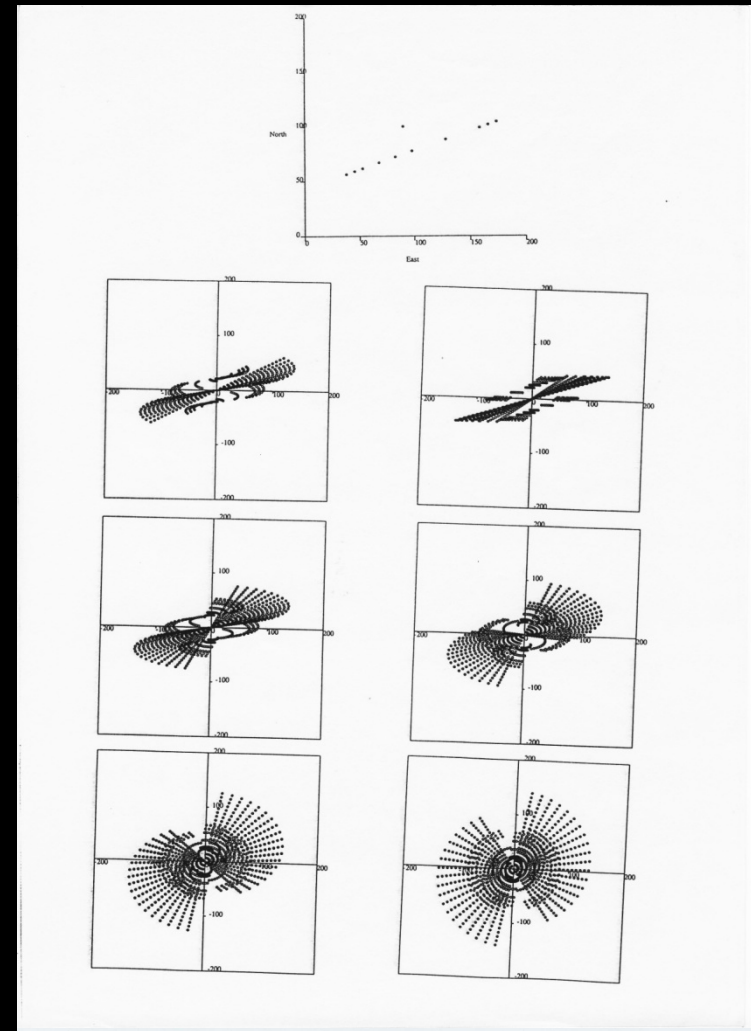
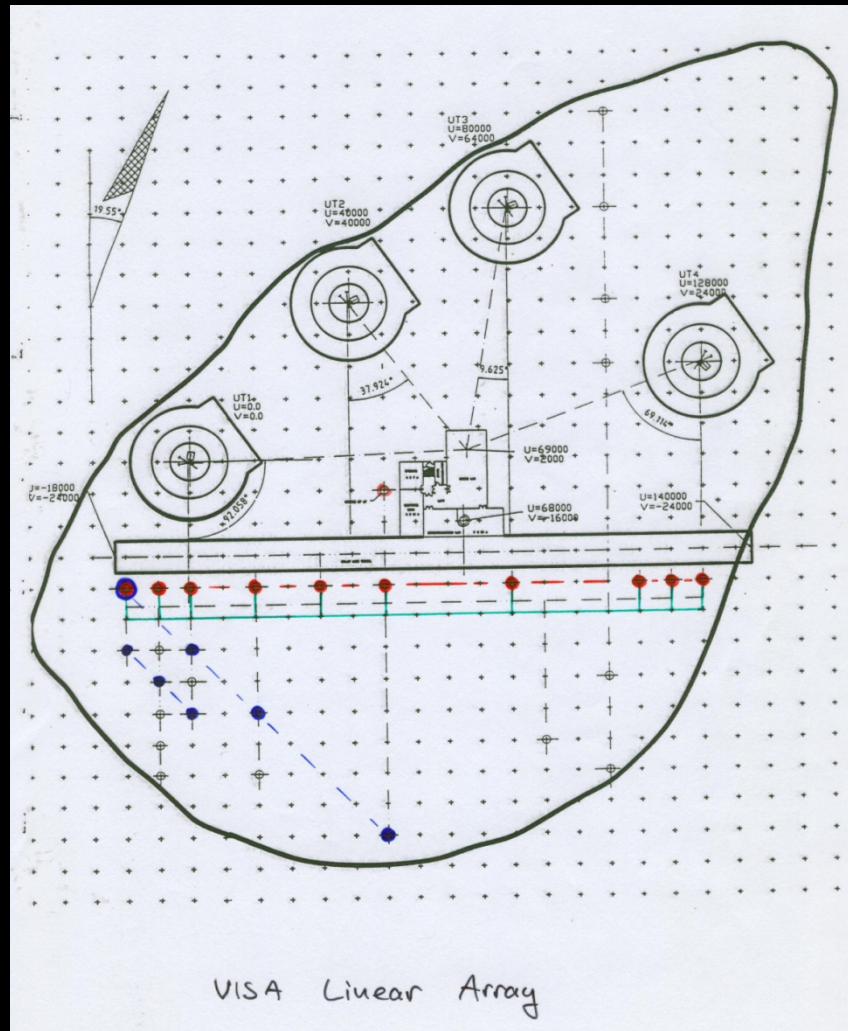

Flexibility of Sub-Array

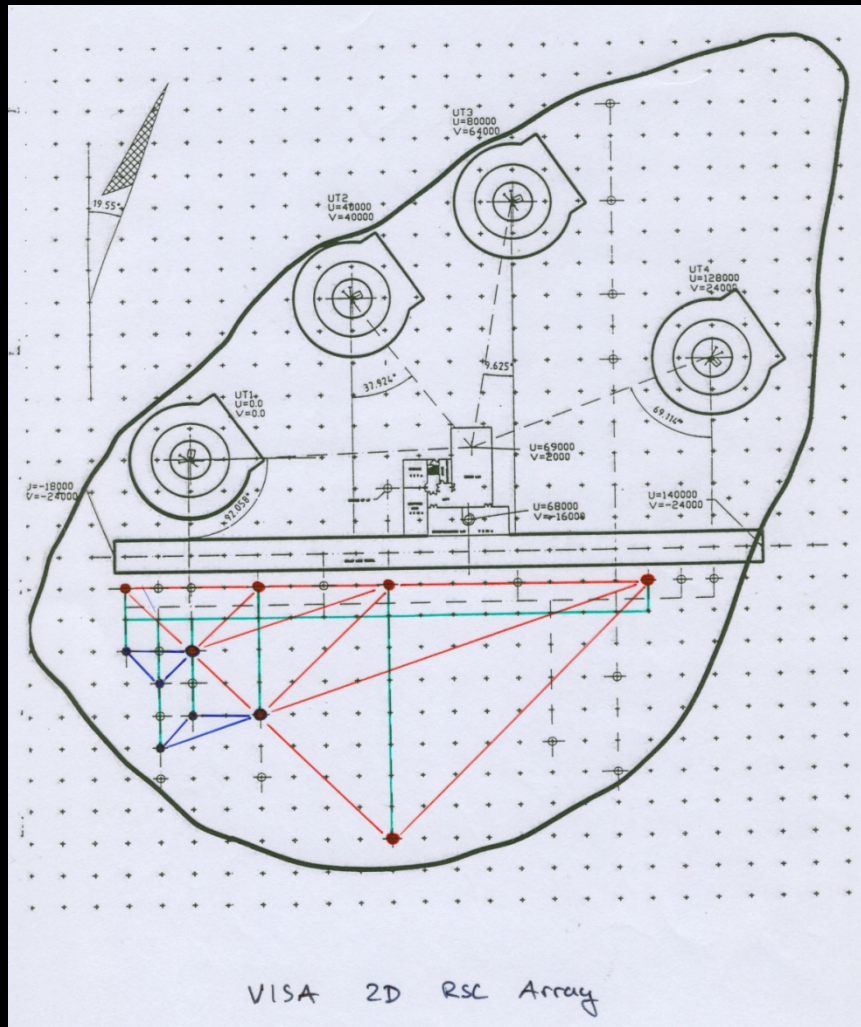

The True History of Beckers' Pit

- One requirement on VLTI was the capability to simultaneously observe IRS7 and the Galactic Center (Sgr A*)
- This means an 8 arcsec FOV

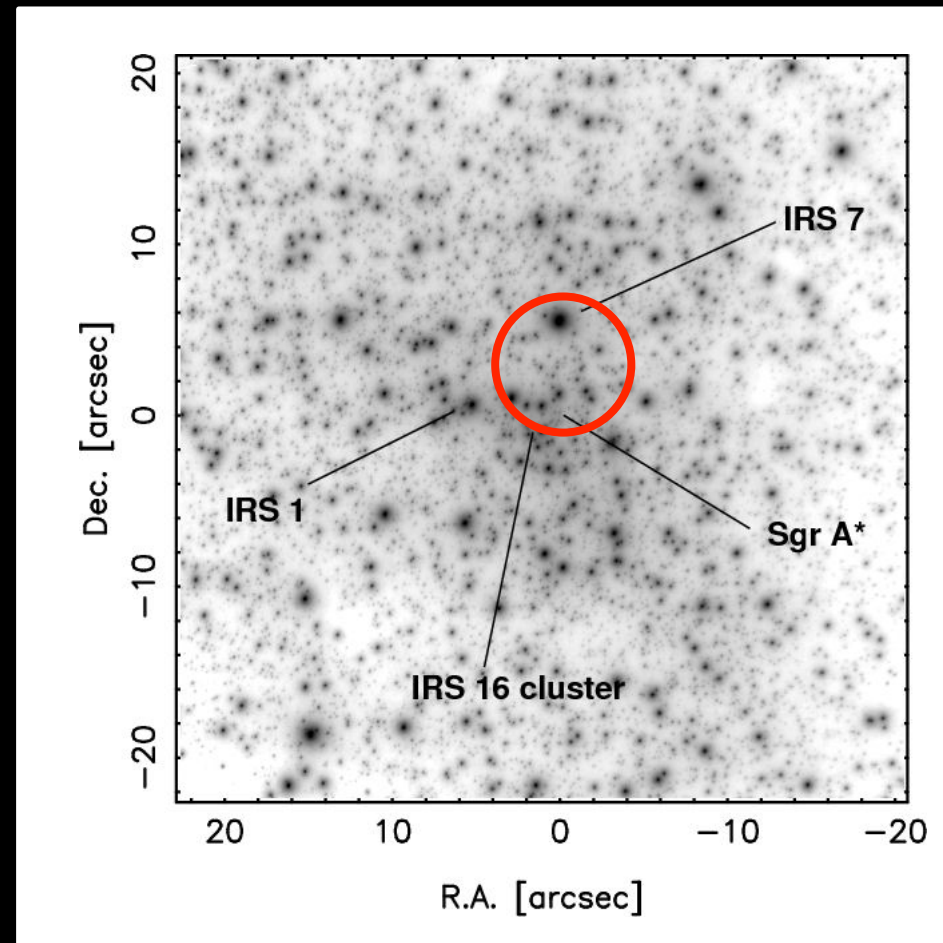

Schödel, R., Merritt, D., Eckart, A., A&A 502,1 (2009)

The True History of Beckers' Pit

- The delay lines became huge beasts
 - Reflector optics with 80cm diameter
- A homothetic mapper for an image beamcombiner was a necessity

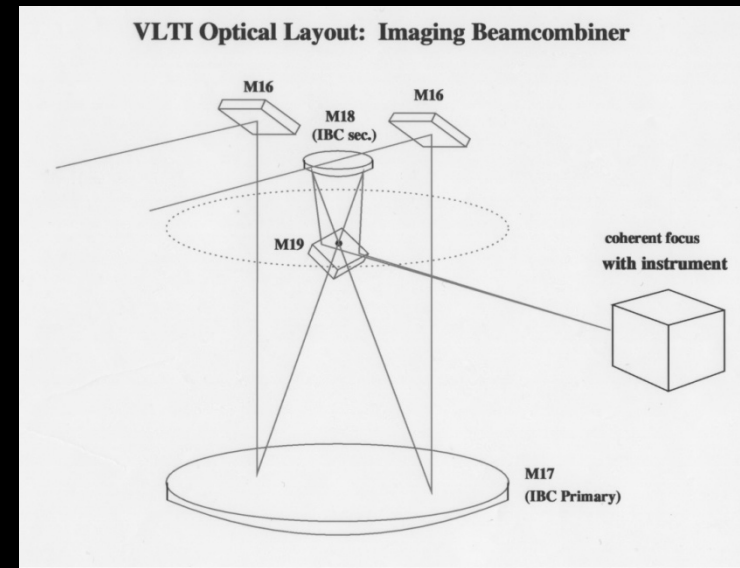
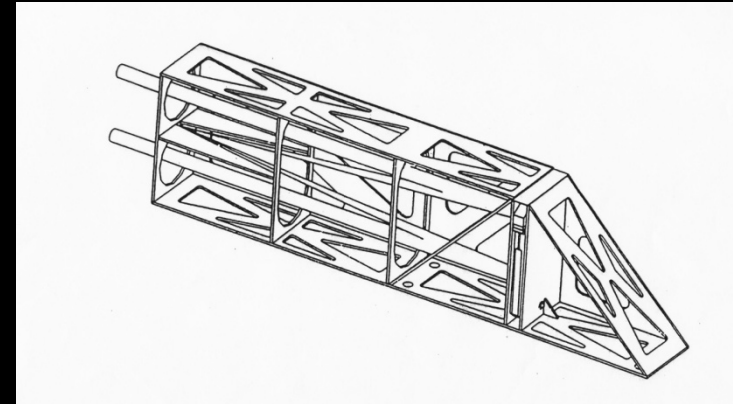

The True History of Beckers' Pit

- The coherent lab has an 8m deep pit to take up the Imaging Beamcombiner

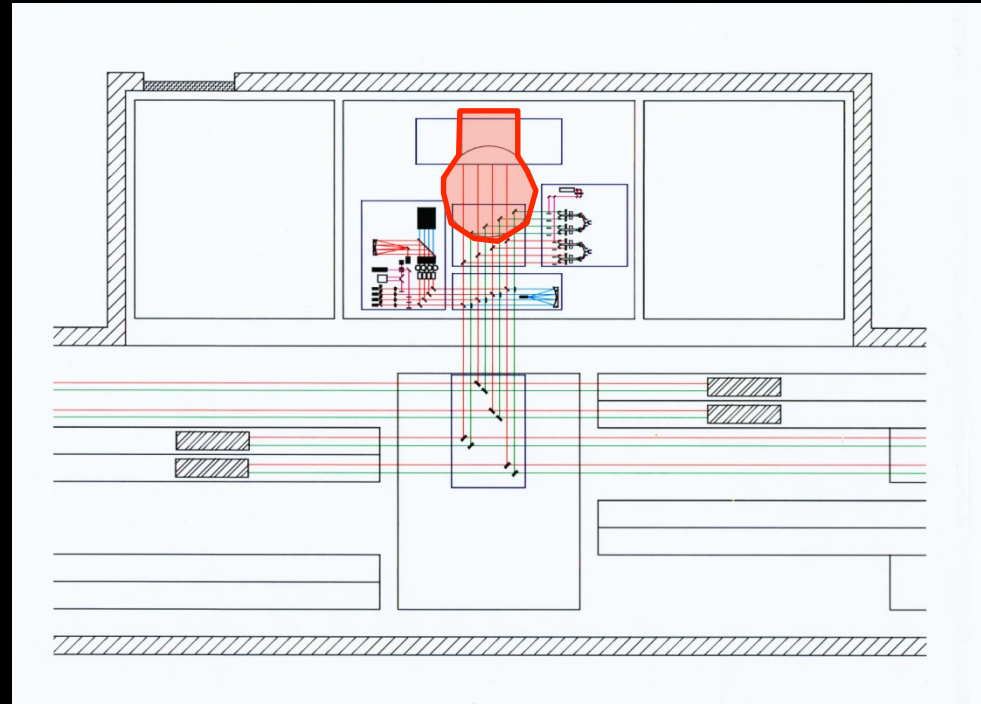

Interferometry lab layout, approx. 1997

The True History of Beckers' Pit

Imaging Beamcombiner Description

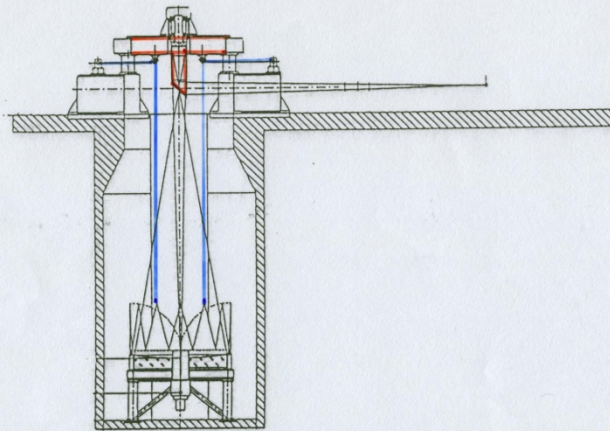

Gregory concept

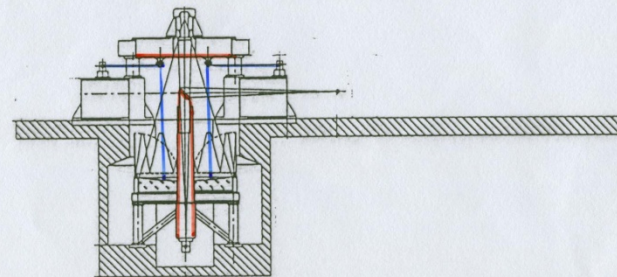

Cassegrain concept

ESO definition study

Tradeoff between R/C Cass.
and Gregory concept

basic design implements fixed,
reconfigurable output pupil

advanced design includes
homothetic mapper
(continuously reconfigured
exit pupil with 0.05mm
precision)

Homothetic mapper and IBC telescope concepts by Zhu Nenghong

The Postponement Crisis

- ESO Council decided in October 1993 to postpone the development of VLT1 to a time after the Unit telescopes were completed
- This decision was based on the mismatch between funding and spending profiles for the VLT project, forcing ESO to borrow money in the later 1990s in order to complete the project in time and in budget

The Postponement Crisis

- The postponement of VLTi had a devastating effect on the morale of the interferometry community
- Steps taken by the DG to remedy the situation:
 - Instructed the VLTi group to „continue with research and development“ at a moderate level
 - Entered into negotiations with CNRS and MPG to assure the external financing of a third Auxiliary Telescope
 - Instructed the VLT project to develop a new implementation plan for VLTi

... and its consequences

- VLTi became a project with heavy community participation
 - Continuation of VCM and fringe tracker prototype development (the latter became FINITO)
 - Community supplied Auxiliary Telescopes (original ESO proposal included 2 ATs)
 - Beam combination instruments as community contributions (MIDI and AMBER)
 - VLTi Steering Committee
- The VLTi group increased from 1994 onwards

... and its consequences (contd.)

- The VLTI concept was heavily modified to accommodate a given budget envelope
- As a consequence, the 8" FOV was reduced to 2" and the imaging beamcombiner was dropped
- The delay lines became much smaller and simpler
- The delay lines included a second beam (PTI concept)



Conclusions

- Real metal was cut on VLTi subsystems only after my departure (spring 1997)
- Many aspects of the VLT Interferometer today have their roots in the early 1990s
- VLTi was – and is – an ambitious endeavor, and arguably the best funded interferometer world-wide