

# Advanced high-cooling power 2-stage Gifford-McMahon refrigerator systems

Gerd Jakob\*\*<sup>a</sup>, Jean-Louis Lizon<sup>a</sup>

<sup>a</sup>European Southern Observatory, Karl-Schwarzschild-Strasse 2, 85748 Garching bei München, Germany

## ABSTRACT

This paper describes the development of high-cooling power systems by making use of multiple cold head operation with a minimized number of compressor units. These advanced cooling systems were investigated for optimization and their Carnot efficiencies were analyzed. Test series were performed to monitor and rank some of their critical operation parameters. Operating envelopes for different cold head / compressor configurations were defined for applications in various VLT instruments. This new concept of providing high pressure helium as a service point for a large number of detached cold heads is a first step towards a new cryogenic facility concept for the E-ELT.

**Keywords:** Cryogenics, high-cooling power, multiple cold heads, Gifford-McMahon

## 1. INTRODUCTION

Powerful cryogenic instruments for ground-based astronomy often require very high cooling power. To cool the several independent temperature levels for detectors, different sub-structures and thermal shielding three or even more cryocoolers are required. Standard industrial-type 2-stage Gifford-McMahon (GM) refrigerators were selected earlier [4] to serve as reliable cooling devices, known to implement proven technology, low vibrations, orientation-free operation, adjustable frequency and practicable mean-time-between-failure (MTBF) respectively service intervals. Although well-engineered and optimized, due to physical limitations their Carnot efficiencies are reaching just a few percent. Therefore one cannot expect much more than typically 100 W of cooling power at 80 K for a single system, already demanding several kW of compressor input power.

The National Institute of Standards and Technology (NIST) published capacities and efficiencies of several different cooling principles, also containing Gifford-McMahon refrigerators with their typical 10-100 W cooling power. Their efficiencies at  $T = 80$  K spread from 3-10% for compressor inputs of 0.7-6 kW (figure 18).

Our selected 20 K two-stage cryocooler COOLPOWER 10MD from Oerlikon Leybold is originally designed to operate one cold head with one compressor. Each system is known to have a power consumption of about 6 kW to provide refrigeration capacities of 10 W @20 K and 100 W @80 K. Instrumentation with three or more cold heads would therefore require at least 18 kW input power or accordingly more. The main task of this work package was to find solutions how the input power could be reduced to a more compliant value while still obtaining adequate cooling power of the cryocoolers. The project investigates in detail the feasibility of operating a certain number of cold heads  $n$  ( $n \geq 2$ ) with a smaller number of common compressors  $m$  ( $m < n$ ) and whether the performance of classical GM cryocoolers can be extended by realization of advanced multiple refrigerator systems with ultra-high cooling power of up to several hundred Watts still achieving the relatively high efficiencies of sophisticated GM machines (5-10% of Carnot).

## 2. TEST SET-UP

A cryocooler test bench was set-up which is presently able to accommodate three compressors, two standalone power modules and four vacuum vessels with four cold heads. Synchronal operation of up to three cold heads and two compressors has been implemented. An upgrade to bigger systems is technically feasible. In order to evaluate the partly very critical operation parameters of these newly developed advanced refrigerator systems a wide variety of measurement equipment was additionally implemented.

\*gjakob@eso.org; phone +49 89 32006131; fax +49 89 32006530; www.eso.org

## 2.1 Cold head and vacuum vessel

The cold heads were separately mounted in special designed vacuum vessels each. The vessels were equipped with pressure gauges, valves and electrical feed-throughs. They were all helium leak tested to have a leak rate better than  $10^{-9}$  mbar\*1/s, as vacuum leaks can have serious influence on measured cooling power. The cold head temperature stages were equipped with temperature sensors and power heaters. Four of these devices were mounted in the test bench to be interconnected by vacuum bellows and valves to a common pumping unit.

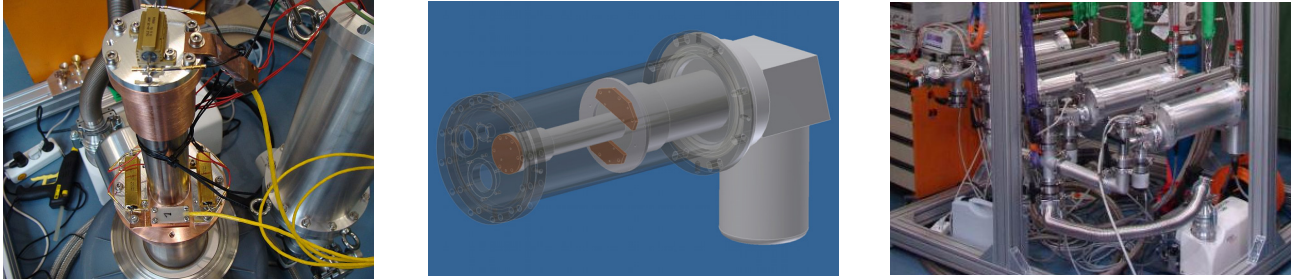

Figure 1: CP10MD with power heaters and temperature sensors (left), cold head and vessel (middle), test bench with vacuum assembly and four cold heads mounted in four separate vessels (right)

## 2.2 Compressor and power module

The Oerlikon Leybold CP10MD system is initially designed to operate one COOLPOWER cold head with one helium compressor COOLPAK 6000MD. It should be investigated how a certain number of cold heads  $n$  ( $n \geq 2$ ) can be operated with a smaller number of compressors  $m$  ( $m < n$ ). A first step in this direction is to theoretically split up the two main functions of the compressor in a) high pressure helium supply and b) cold head drive. The second step is to provide as many cold head driving units (so called power modules) as there are cold heads to be driven. This can be compressor internal and/or so called standalone power modules. In a third step some electrical modifications have to be applied to the power modules. This is necessary to take advantage of one of the safety circuits inside the compressor unit, measuring the current through one of the scroll electrical phases (L3) and in case this goes to zero (scroll stopped due to any other failure) also the cold head drive stops. With a few simple modifications it was possible to realize serial connections of compressors and standalone power modules including this safety shut down for all units. Special interconnection cables were introduced to close the L3 current measurement loop through all modules. Oerlikon Leybold is in parallel developing a new compressor series with a horizontal cryoscroll. This arrangement has advantages for a better oil management and also offers an expanded and advantageous helium pressure operation envelope (figures 8, 9, 10). Oerlikon Leybold was kindly providing one of these CP6000H Betaside units for performance tests with our bench.

## 2.3 Helium buffer reservoirs

The supply of multiple cold heads with high pressure helium gas is realized by means of so called buffer reservoirs. These are custom made stainless steel vessels filled with helium gas to nominal static pressure (15 bar). They are interconnected between the compressor(s) and the cold head(s), one in the high pressure and one in the low pressure helium line. Each of them has one input and three outputs ports. It is also feasible to increase the number of outputs if needed for future applications. In case of multiple compressor applications, the input ports can be additionally equipped with standard helium gas distributors. The standard buffer vessels have a volume of 5 Liter. Two different types were tested a) standard helium buffers as described above and b) water cooled helium buffers.

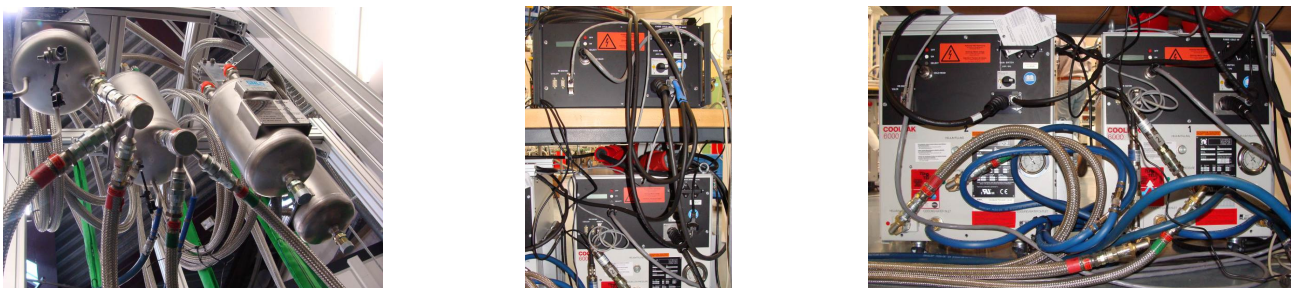

Figure 2: water cooled and standard buffers (left), power module (middle), two parallel compressors with interconnections (right)

## 2.4 Remote start

In 2.2 we describe the implementation of the wanted safety shut down of all cold heads in case of scroll compressor failure. The response time is very small, 5 seconds after the L3 phase current drops below a certain level the power module shuts everything down. Therefore it is necessary to start all modules simultaneously. The CP6000MD power module offers a standard Sub-D connector interface for accessing the on/off switch remotely. A special developed remote control allows simultaneous compressor(s) and cold head(s) starting and stopping. This principle may also be upgraded to control more than three devices.

## 2.5 Schematics of advanced single and multiple refrigerator systems

The following versions called V1, V2, V3 and V3\_2 were built and comprehensively tested:

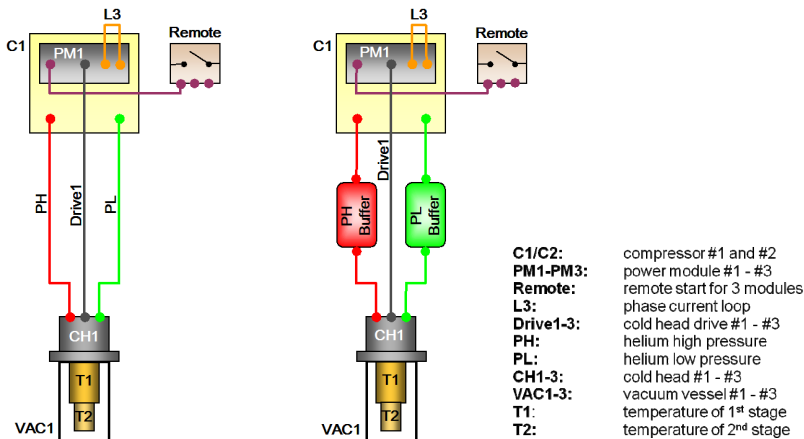

Figure 3: V1: 1 cold head / 1 compressor, without and with helium buffers

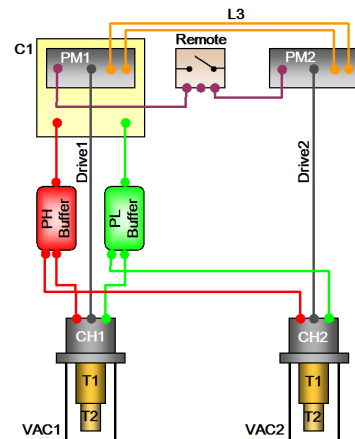

Figure 4: V2: 2 cold heads / 1 compressor

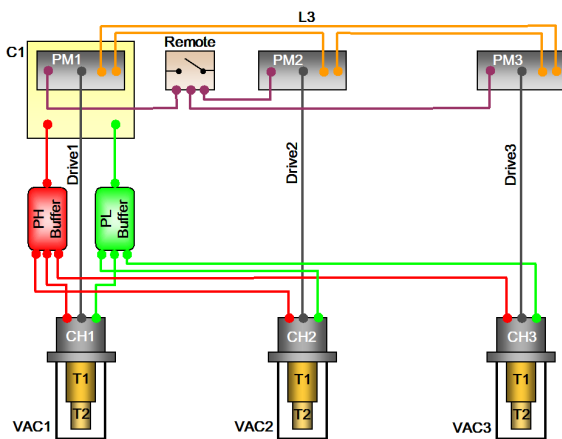

Figure 5: V3: 3 cold heads / 1 compressor

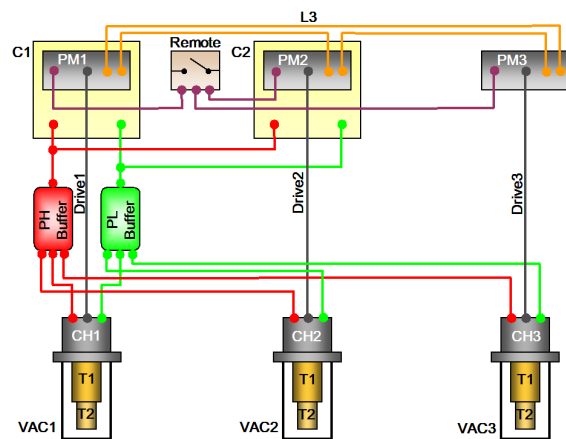

Figure 6: V3\_2: 3 cold heads / 2 compressors

## 2.6 Input power control

The compressor input power is a critical parameter which is recommended to be monitored continuously during operation of multiple cold heads. It is also an important quantity for the system efficiency determination. The current of one compressor electrical phase was measured using a clamp-on ampere meter. Any of the three phases could be selected, but just L3 was monitored representatively during all test runs. Measured values are transferred in real time via USB interface to the data evaluation notebook.

## 2.7 Compressor temperature monitoring

The compressor temperature can be a critical factor for operation in extreme environments. The CP6000MD is a water cooled unit which, when operated with nominal cooling water conditions, in middle European standard temperature and humidity environment never showed any overheating problem. But as it is planned to use them in the very dry climate of the VLT high site, it is worth to investigate how this device behaves under different conditions by checking a few specific compressor internal temperature spots. Four thermocouples were placed inside the compressor unit to measure the temperature of certain spots. Data are recorded by a 4-channel real time logger and are transferred to the PC by USB interface. Measured temperatures serve as input for later system efficiency calculations.

## 2.8 Helium pressure monitoring

The most critical operation parameter is the system helium pressure. The CP6000MD cryoscroll compressor is designed to work within a restricted operation envelope (figure 7, right), represented by certain ratios of helium high (discharge pressure) to low pressure (suction pressure). Operating it outside of this envelope has to be avoided in order to not risking an oil circuit failure which shuts down the unit or can even cause serious damage. Two pressure transmitters were implemented in the set up, one in the helium high and one in the low pressure line. They were mounted with T-pieces into the helium flex line connection close to the compressor. Data are logged by a 2-channel hand held recorder to be transferred to the PC via serial interface.

## 3. HELIUM PRESSURE OPERATING ENVELOPE

For all single and multiple refrigerator systems the main focus was first put on the critical helium pressure operating envelope. After finding admissible operating conditions cooling power and compressor input power were determined.

### 3.1 Helium pressure at nominal motor frequency

While operating the systems at nominal motor speed of 120 rpm (2 Hz) and with no dissipations applied to their 1<sup>st</sup> and 2<sup>nd</sup> stages (radiation load only) the helium high and low pressure was measured as described earlier in this report. For all configurations the characteristics were then analyzed regarding the critical cryoscroll operating envelope. As a general rule the ratio of high to low pressure must be above 2.3. This fictive limit is indicated as black dotted line in the transient plot and is approximately represented by the lower diagonal line of the operating envelope in the right plot of figure 7. After the cool down settlement the high and low pressures are stabilizing at certain values defining a working point inside or outside the CP6000MD operation envelope. The V1 configuration was tested without and with buffer implementation. For both the helium pressure ratio of 3.3 is uncritical and the working point is well centered within the envelope (green and violet curves). With a value of 2.0 the helium pressure ratio of this V2 configuration is too small and has to be avoided for permanent operation. The lower end of the red curve is clearly outside the envelope. Although being far away from its ideal operation parameters this system configuration was successfully cooled down and ran four times without any incident. As a worst case test one of the V2 sequences was running for more than 50 days.

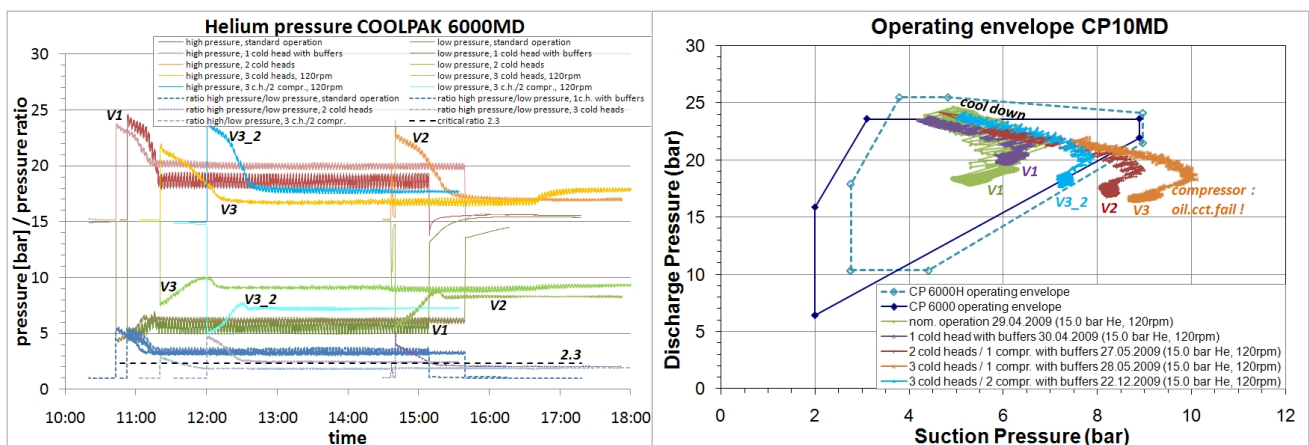

Figure 7: helium pressure characteristics of V1, V2, V3 and V3\_2 configurations at 120 rpm, high and low pressure transient (left), operating envelope (right)

For V3 the conditions are even worse. With a pressure ratio of just 1.89 the working point moved even further out of the CP6000MD operating envelope. This is basically caused by the higher helium low pressure. After a few hours of operation at 120 rpm the V3 system stopped with an error message. The oil circuit sensor of the compressor raised an alarm (oil.cct.fail) and the internal electronics stopped the cryoscroll. As described earlier this event triggered subsequently the safety shutdown of the cold head drives. That action did not cause any damage of the compressor and it could be recovered after some hours of chilling. But it is evident that the system cannot be operated reliably with these settings. With a value of 2.45 the helium pressure ratio of this V3\_2 configuration is acceptable and the working point is just within the envelope (light blue curve).

### 3.2 Helium pressure at variable frequencies

Nevertheless the envelope violations of V2 and V3 are a problem. There are two possible approaches for a solution:

1. The cold head's 1<sup>st</sup> stage is in our applications practically loaded with high dissipations (75-125 W), which shifts the working point towards higher pressure values and therefore closer to the cryoscroll operating envelope.
2. The COOLPOWER 10MD is offering the great advantage of regulating the motor revolution. This can be done in the range of 20-160 rpm by increments of 10 rpm. Lower motor speed corresponds also to smaller helium low pressure values which is beneficial for running the system within the operating envelope.

Figure 8 shows the V2 helium pressure characteristics for two 1<sup>st</sup> stage load cases (0 W and 75 W for each of the two heads) combined with variable motor revolution. The practically unrealistic curve of an unheated 1<sup>st</sup> stage shows that only the working points achieved with motor revolutions smaller than 60 rpm are located inside the envelope. 70 rpm is at the edge of the CP6000MD envelope, while higher revolutions have pressure ratios below the critical limit of 2.3 and are to be avoided. As expected the curve is shifted towards higher pressure values when for example each of the 1<sup>st</sup> stages is loaded with 75 W. With high loads on the 1<sup>st</sup> stage the usable range becomes much wider and all motor revolution settings below 120 rpm are admitted.

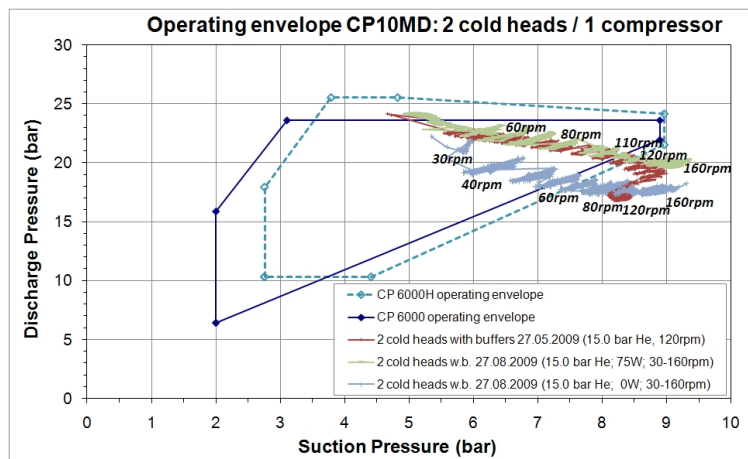

Figure 8: helium pressure characteristics of V2 config.: 2 cold heads / 1 compressor at variable motor speed and different load cases

Figure 9 illustrates the V3 helium pressure characteristics for different 1<sup>st</sup> stage load cases (0-70W for each of the three heads) combined with variable motor revolution (50-120 rpm). Each different color shade represents a different setting. It is obvious that there are just a few working points inside the admissible envelope. In addition a simplified model is applied showing straight lines for constant motor revolution (green), constant 1<sup>st</sup> stage load (black) and constant 1<sup>st</sup> stage temperature (red). The black dots inside the color shaded areas represent the most likely working points. By means of this diagram one can get all required information on a glance. There are the acceptable working points with pressure ratios above 2.3 on one hand and the according 1<sup>st</sup> stage temperatures respectively cooling power on the other hand.

The V3\_2 helium pressure characteristics for different 1<sup>st</sup> stage load cases (0-100W for each of the three heads) combined with variable motor revolution (50-160 rpm) is shown in figure 10. Each different color shade represents a different setting. Almost all investigated working points are inside the COOLPAK 6000MD cryoscroll operating envelope. Only at very high motor revolutions (>120 rpm) the envelope boundaries are reached or exceeded. But as the helium pressure rate is still above 2.3 for all measured settings, there are no restrictions within the investigated reasonable motor revolution range of 50-160 rpm combined with typical 1<sup>st</sup> stage loads up to 125 W for each head.

It is quite apparent that for multiple cold head use the horizontal scroll compressor CP6000H would offer a more advantageous operating envelope. One would gain by 10-20 rpm higher motor speeds which would induce accordingly higher 1<sup>st</sup> stage cooling power.

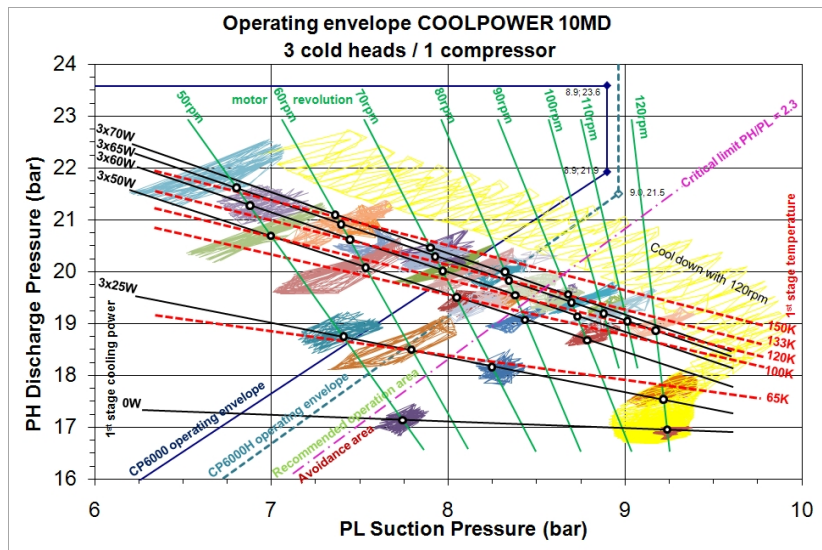

Figure 9: helium characteristics for V3 configuration: 3 cold heads / 1 compressor at variable motor speed and different load cases

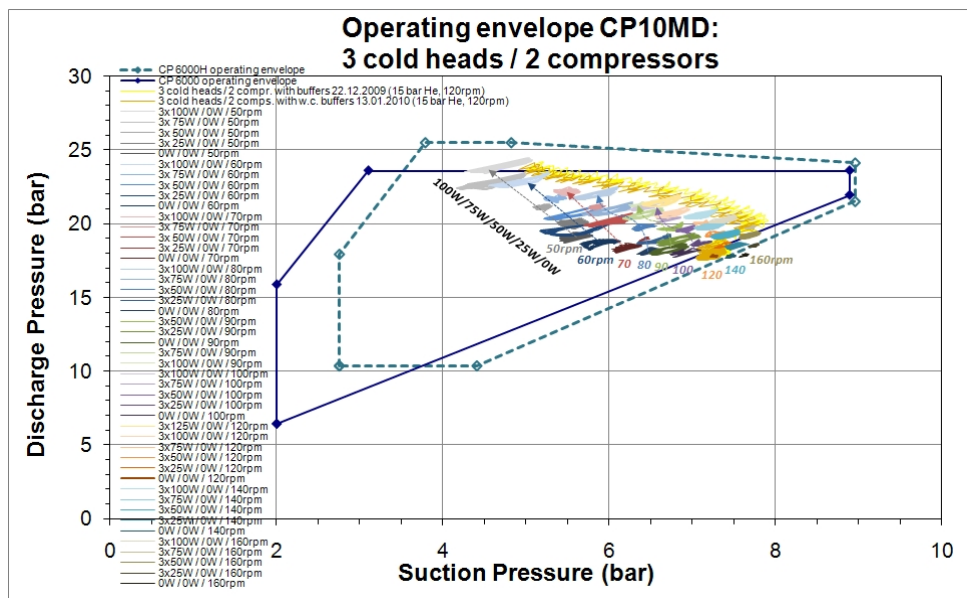

Figure 10: helium pressure characteristics of V3\_2 configuration: 3 cold heads / 2 compressors at variable motor speed and different load cases

#### 4. REFRIGERATION POWER

First of all several different modifications of the standard configuration 1 cold head / 1 compressor (V1) were tested. It could be proved that the implementation of helium buffers, the length of the helium flex lines (6 m/20 m) and additional compressor cooling are not significantly affecting the refrigeration power. With using the horizontal CP6000H compressor it has been discovered that the cooling powers of the 1<sup>st</sup> and 2<sup>nd</sup> stages are about 10% lower than with the standard CP6000MD. A comprehensive cryocooler survey [4] showed that the CP10MD system is the most powerful of its class, so the benefit of an expanded helium pressure operation envelope as offered by the CP6000H could be the more important factor.

#### 4.1 Cooling power of single systems V1

In total four cold heads were tested revealing variations in their cooling power up to almost 20%. The average values of first and second stage were used for further comparisons with multiple systems.

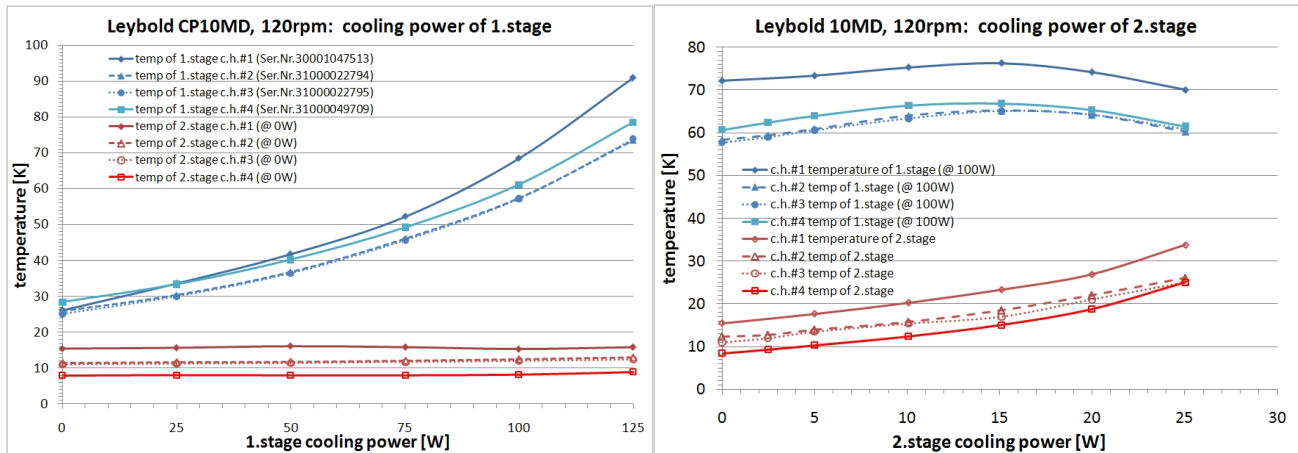

Figure 11: cooling power of four individual CP10MD cold heads, 1.stage (left) and 2.stage (right)

Table 1: CP10MD cooling power in standard configuration V1

Cold head number	1 <sup>st</sup> stage cooling power	2 <sup>nd</sup> stage cooling power (1 <sup>st</sup> stage powered with 100 W)
1	108 W @75 K	10 W @20 K
2	125 W @75 K	17 W @20 K
3	125 W @75 K	19 W @20 K
4	120 W @75 K	21 W @20 K

The COOLPOWER 10MD is offering adjustable motor revolution. This can be executed within the range of 20-160 rpm by increments of 10 rpm. How the cooling power is depending on the selected motor speed is shown below. Cold head #1 in standard configuration V1 was used for this test.

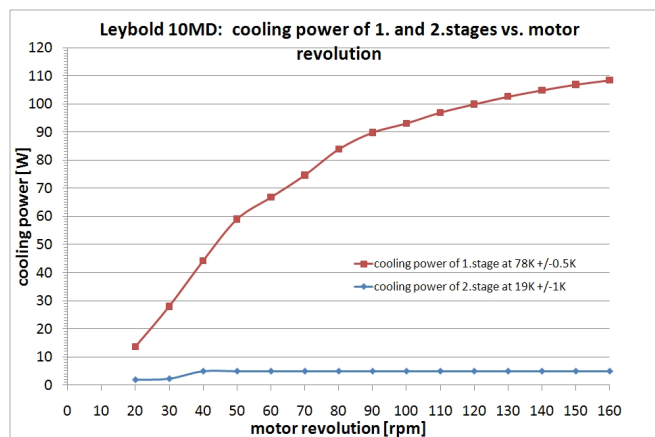

Figure 12: Oerlikon Leybold CP10MD cooling power at variable motor revolution, compared to operation at nominal motor speed 120 rpm the 1<sup>st</sup> stage cooling power decreases at 80 rpm by 16% and at 60 rpm by 33%

#### 4.2 Cooling power of multiple systems V2, V3, V3\_2

The powerful 1<sup>st</sup> stage cooling capacities of all above described single and multiple Gifford-McMahon refrigerator systems are shown in figure 13. Here the total cooling power values are corrected by the initial radiation load. A lump sum of 5W was assumed for each head and temperature stage. The standard configuration V1 (1 cold head / 1

compressor) is represented by a mean value of three cold heads. As stated earlier the actual cooling power of individual heads can vary up to 20%. For comparison the most powerful head (cold head #3) is shown in addition.

V2 and V3 have different curvatures than V1 and V3\_2 as they have to be operated at reduced motor speeds for small 1<sup>st</sup> stage loads. Accordingly lower cooling power lead to these actually uncharacteristic straight lines. Therefore, below 100 W V2 has less total cooling power than V1 but above it is similar or even better. Compared to V1 or V2 the 3-heads configuration V3 has in its whole range a somewhat lower total cooling power because the motor speed is limited to 60 rpm or max. 80 rpm (-33% respectively -16% cooling power).

The V3\_2 (3 cold heads / 2 compressors) cooling power 290 W @80 K is even more than the mathematical prediction. Three single heads with three compressors would provide 3\*128 W = 384 W. One compressor less implies a correction factor of 2/3 which would just predict 256 W. V3\_2 offers a gain of 13% in cooling power. Similar results are obtained for V2 and V3 at higher loads. At 80 K V2 is offering a gain of 17% in total cooling power compared to average V1.

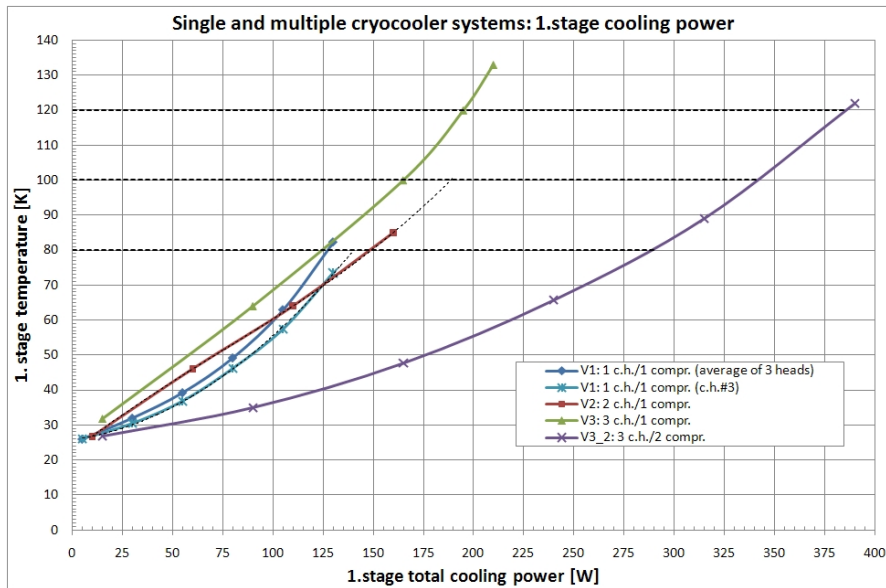

Figure 13: 1.stage cooling power of different configurations operated at their recommended motor frequencies

Table 2: 1.stage cooling power of single and multiple cryocooler systems

1 <sup>st</sup> stage temperature level	Total 1 <sup>st</sup> stage cooling power in W / 1 <sup>st</sup> stage cooling power per cold head in W				
	V1 (average of 3 cold heads)	V1 (c.h.#3)	V2	V3	V3_2
120 K				195 / 65	385 / 128.3
100 K			187 / 93.5	165 / 55	342 / 114
80 K	128 / 128	140 / 140	150 / 75	125 / 41.7	290 / 96.7

As a first approximation the following correlations are applicable for both temperature stages of these advanced single and multiple GM refrigerator systems:

- Primary the number of compressors  $m$  defines the quantity of total cooling capacity  $Q_c$ :  $Q_c \sim m$
  - To obtain the individual cooling power per head the total cooling capacity has to be divided by the number of heads  $n$ :  $Q_{ci} \sim Q_c / n \sim m / n$
- Therefore:
- |       |             |                              |
|-------|-------------|------------------------------|
| V1:   | $m=1; n=1;$ | $Q_{ci} = Q_c$               |
| V2:   | $m=1; n=2;$ | $Q_{ci} \approx Q_c / 2$     |
| V3:   | $m=1; n=3;$ | $Q_{ci} \approx Q_c / 3$     |
| V3_2: | $m=2; n=3;$ | $Q_{ci} \approx 2 * Q_c / 3$ |

But as shown above there are fine tuning exceptions which can make the difference. Particular configurations offer a gain in refrigeration power of up to 17% compared to others. Further optimization is feasible.



Investigations on the 2<sup>nd</sup> stage cooling power of multiple refrigerator systems were performed as well. As an average value of three cold heads V1 provides more than 15 W @20 K /120 rpm (radiation correction is not applied). V3 offers just 13 W @20 K /80 rpm. This can be explained by the ~16% loss in cooling power due to reduced motor speed. While V1 is providing 15 W per head, V3 offers just a 2<sup>nd</sup> stage cooling power of 13 W /3 = 4.3 W per head at the same temperature level. The curve of the V2 2<sup>nd</sup> stage cooling power is unexplained. But as only the 2<sup>nd</sup> stage temperature of cold head #2 was increasing quite extreme, a leak in vacuum vessel #1 might have been the cause. V2 curve is actually expected to be more similar to V3. Note: presented measurements were performed with the following loads applied to the 1<sup>st</sup> stages: V1: 100 W; V2: 2\*50 W = 100 W; V3 = 50 W + 60 W + 70 W = 180 W.

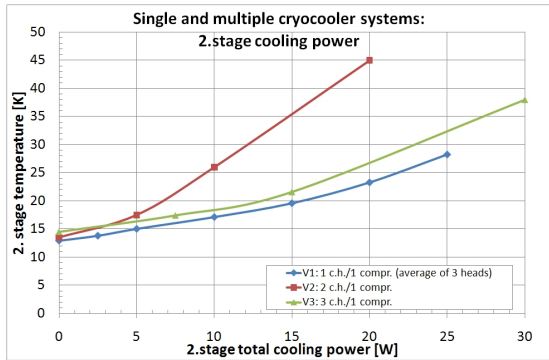

Figure 14: 2.stage cooling power of different configurations at their recommended motor revolutions

**4.3 Recommended operation**

From the obtained measurements a recommended operation envelope for the multiple cryocooler systems can be defined. The green area represents working points inside the CP6000MD operation envelope with helium pressure ratios above 2.3. Combinations of 1<sup>st</sup> stage dissipations and motor revolutions out of the green area are not allowed. For practical handling it is recommended to always cool down the system at nominal motor speed 120 rpm and to change revolution for all heads to admissible values once helium pressure values have settled.

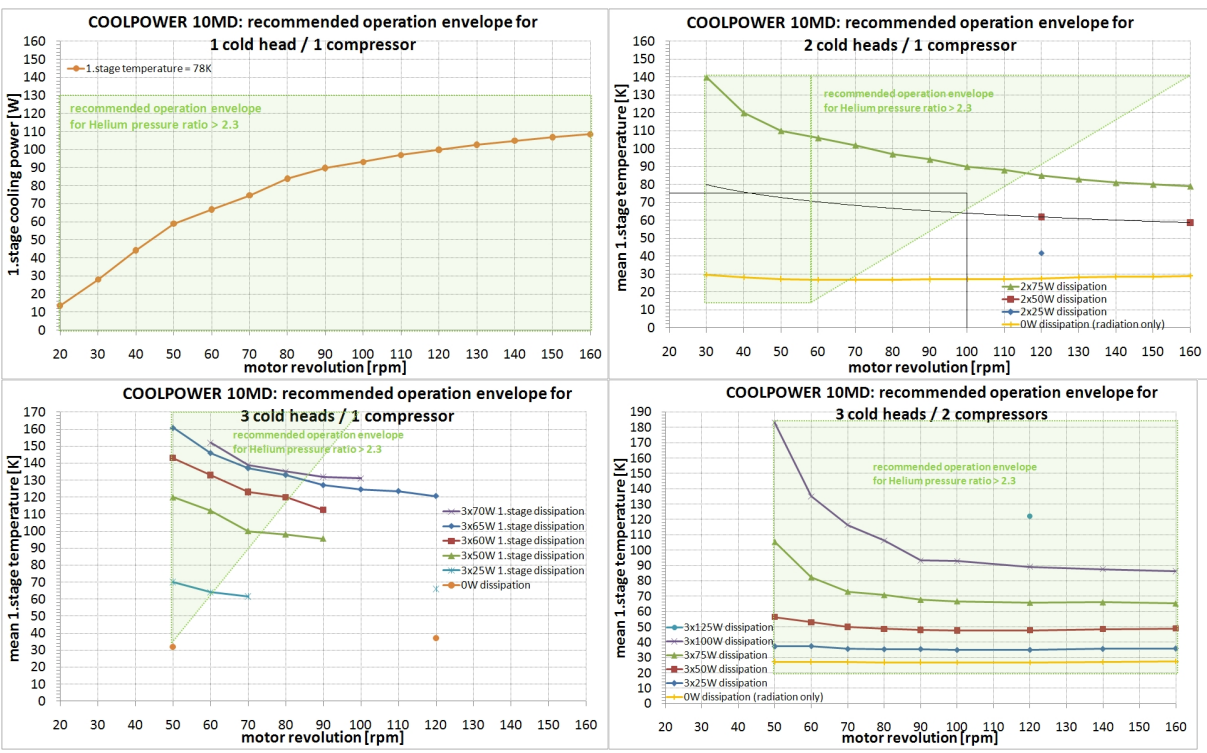

Figure 15: 1.stage cooling power and recommended operation envelopes for V1, V2, V3 and V3\_2 configurations

## 5. COMPRESSOR INPUT POWER

The compressor power consumption was monitored by measuring the current  $I_{L3}$  through phase L3. The obtained values were transferred into power regarding the effective 3-phase AC voltage. For all systems different load cases and motor frequencies were investigated. Generally the input power increases with higher cold head loads and with reduced motor speed (figure 16). Operating cold heads with zero heat load at 120 rpm requires typically 4.5 kW per compressor unit. With typical 1<sup>st</sup> loads of 50-125 W and 5-10 W for the 2<sup>nd</sup> stage the consumption per compressor increases to around 5 kW. During cool down peaks of almost 6 kW are reached.

One of the major achievements of multiple systems is the reduction on the input side. Each compressor less saves about 5 kW. Provided a given instrument depending quantity of cold heads and the acceptable constraints in cooling power per head V2 or V3\_2 save about 5 kW compared to two respectively three parallel single V1 systems. V3 saves even up to 10 kW input power compared to three single refrigerator systems, provided one can effort the total cooling power splitting as described earlier.

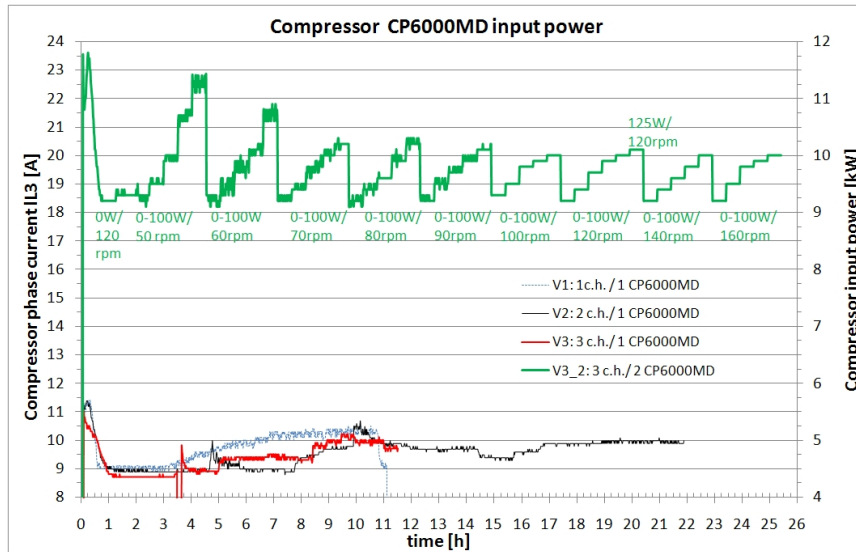

Figure 16: compressor input power of single (V1) and multiple (V2, V3, V3\_2) cryocooler systems

## 6. CRYOCOOLER EFFICIENCY

All presented cryocooler systems are to be analyzed regarding their efficiency of Carnot. The principal equation for the coefficient of performance (COP) of a Gifford-McMahon refrigerator is the same fundamental formula as for the Carnot COP:

$$\text{COP}_{\text{Carnot}} = Q_c / W_o = T_c / (T_h - T_c) \quad (1)$$

$Q_c$  = cooling power,  $W_o$  = ideal Carnot input power,  $T_c$  = cryo temperature,  $T_h$  = hot temperature (ambient)

The efficiency of Carnot is defined as:  $\eta = \text{COP}_{\text{Real}} / \text{COP}_{\text{Carnot}} \quad (2)$

The real cryocooler COP:  $\text{COP}_{\text{Real}} = Q_c / W \quad W = \text{total compressor input power} \quad (3)$

The efficiency of Carnot is:  $\eta = Q_c / W * (T_h - T_c) / T_c \quad (4)$

Equation (4) consists of measurable quantities only, which refer in our set-up accordingly:

$Q_c$  = measured cooling power of cold head stage,  $W$  = measured total compressor input power,  $T_h$  = measured temperature of helium high pressure supply (293 K),  $T_c$  = measured cold head stage temperature.

Figure 17 (left) shows the efficiencies of the four tested systems when operated with their recommended operation parameters. Each of the curves is having a maximum for particular 1<sup>st</sup> stage loads and according motor revolutions. Maximum efficiencies of 6.8-8.8% can be regarded as very good values for GM cooler systems. How the efficiencies degrade with lower motor frequencies is shown in figure 17 (right). This is caused by a mixed effect of cooling power loss and increased compressor input power.

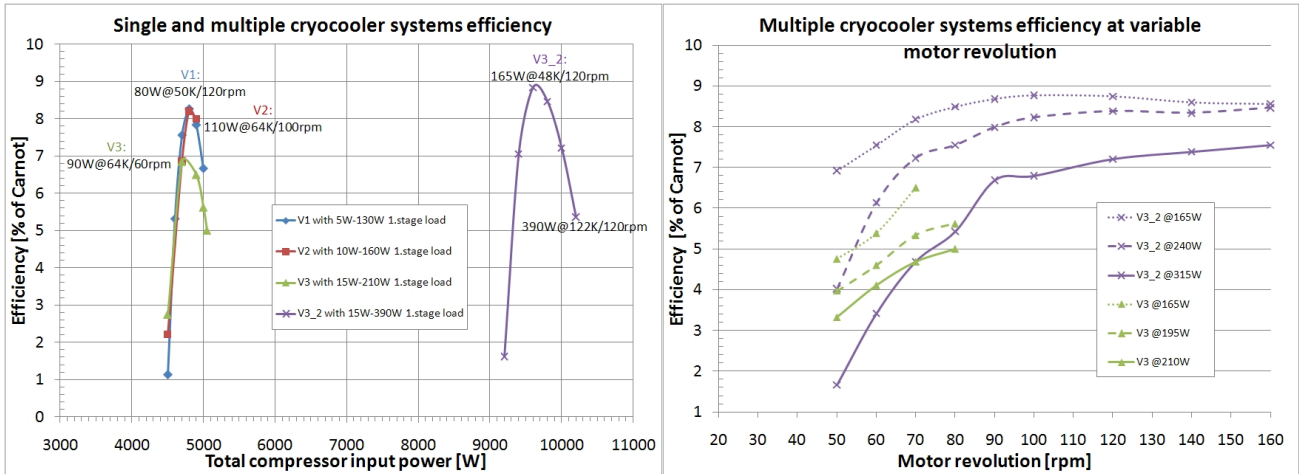

Figure 17: efficiency of cryocooler systems operated at their recommended operating parameters

In order to rank the obtained efficiencies, a comparison with known systems was established. Dr. Ray Radebaugh of NIST published efficiency values of several different cooling principles and machines, also containing Gifford-McMahon refrigerators with typical 10-100 W cooling power. The presented efficiencies at  $T = 80$  K spread from 3-10% for compressor inputs of 0.7–6kW [1, 2, 3].

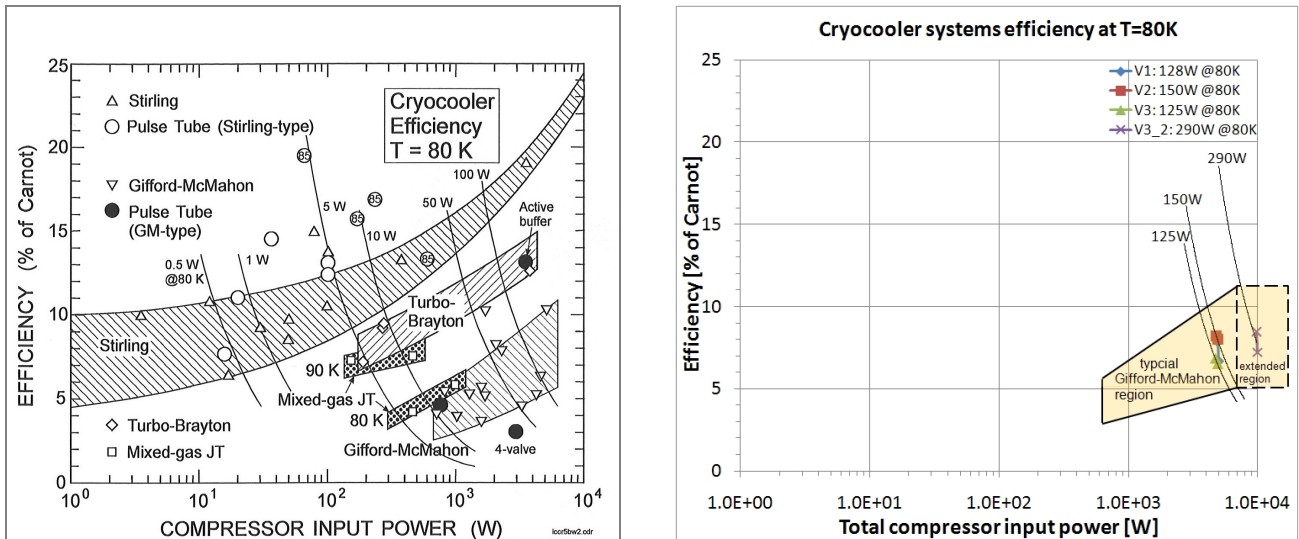

Figure 18: NIST reference cryocooler efficiencies (left), new developed single and multiple systems in comparison (right)

The following efficiencies of Carnot were determined for single and multiple GM refrigerator systems at  $T = 80$  K:

- V1:  $\eta = 7.2\%$  for 128 W @80 K /120 rpm
- V2:  $\eta = 8.0\%$  for 150 W @80 K /110 rpm
- V3:  $\eta = 6.6\%$  for 125 W @80 K /60 rpm
- V3\_2:  $\eta = 8.0\%$  for 290 W @80 K /120 rpm

Regarding their very high cooling power capacities the obtained efficiency values can be ranked as very good. The classical Gifford-McMahon region could even be extended by creation of ultra-high cooling power systems with still fairly good efficiencies:

- V3:  $\eta = 5.0\%$  for 210 W @135 K /80 rpm
- V3\_2:  $\eta = 5.4\%$  for 390 W @122 K /120 rpm

## 7. CONCLUSION

Within this work package a test bench for a comprehensive measurement program on industrial type Gifford-McMahon refrigerators was developed. The bench comprises of four cold heads, three compressors and two additional power modules. Furthermore the test set-up implements equipment to measure relevant quantities like vacuum pressure, cryogenic temperatures, refrigerator cooling power, helium pressure, compressor input power and compressor temperatures.

It was described how a standard cryocooler system with 1 cold head / 1 compressor (V1) can be upgraded to different configurations of multiple cold head / multiple compressor systems. It is demonstrated that the total cooling capacity is mainly defined by the number of compressors in the system. Different approaches were presented how the number of compressors respectively the unacceptable high input power of larger systems can be reduced. Proposed configurations with 2 cold heads / 1 compressor (V2), 3 cold heads / 1 compressor (V3) and 3 cold heads / 2 compressors (V3\_2) can be regarded as demonstrators for up-to-date powerful ground-based cryogenic instrumentation requiring multiple cold heads for several sub-structures, as well as a first step towards a new concept providing high pressure helium as a service point for a large number of detached instrument cold heads. The presented concept can be considered as a potential candidate for the cryogenic infrastructure of future extremely large astronomical telescopes like the E-ELT [5]. Expansion to bigger systems with more than three cold heads is feasible.

Operation parameters were defined and recommendations were given for all tested configurations. A critical analysis was performed to rank their efficiencies. The developed multiple refrigerator systems exceed the classical Gifford-McMahon domain providing high to ultra-high cooling capacities (290 W @80 K / 390 W @122 K) combined with moderate input power. Very good efficiency values from 5% up to 9% of Carnot were achieved. The new powerful refrigerator systems are a valuable advancement of existing state-of-the-art cryocoolers based on reliable and proven technology.

## ACKNOWLEDGEMENTS

The authors would like to thank Oerlikon Leybold Vacuum GmbH and especially their teams in Dresden and München for support and collaboration.

## REFERENCES

1. Radebaugh, R., "Pulse tube cryocoolers for cooling infrared sensors", Proc. SPIE XXVI, Vol. 4130, pp. 363-379 (2000).
2. Radebaugh, R., "Development of the pulse tube refrigerator as an efficient and reliable cryocooler", Proc. Institute of Refrigeration, London (2000).
3. Radebaugh, R., "Cryocoolers: the state of the art and recent developments", J.Phys.: Condensed Matter 21, 164219, 9pp., (2009).
4. Jakob, G., Lizon, J.L., "Low-vibration high-cooling power 2-stage cryocoolers for ground-based astronomical instrumentation", SPIE 7733-139 (2010).
5. Lizon, J.L., et al., "First concept for the E-ELT cryogenic infrastructure", SPIE 7739-159 (2010).