

First concept for the E-ELT cryogenic Infrastructure

J.L. Lizon^{*a}, J.C. Gonzalez^a, C. Monroe^b, I. Bryson^c, D. Montgomery^c

^aEuropean Southern Observatory, Karl-Schwarzschild-Strasse 2, 85748 Garching bei Munchen, Germany

^bC Monroe, Monroe Brothers Ltd, Moreton-in Marsh, Gloucestershire GL56 9AQ, United Kingdom

^cUK Astronomy Technology Centre, Royal Observatory, Blackford hill, Edinburgh EH9 3HJ, United Kingdom

ABSTRACT

The start of the new generation of giant telescopes opens a good opportunity to re-assess the cryogenic cooling of the instruments and detectors. An analysis has been carried out comparing three different technologies: Mechanical cryo-coolers, helium forced flow and open liquid nitrogen cooling. The most different aspects from the running cost to the reliability and technology readiness have been compared in order to establish a fair ranking. The first part of the paper will present in detail the result of this analysis.

Based on this study and the various experiences collected over more than 25 years and a large number of cryogenic instruments, a strategy is elaborated for the cryogenic cooling of the E-ELT (European Extremely Large Telescope) instrument suite.

The challenge consists in providing various cryogenic temperatures (from 10 K to 240 K) at various locations. This should be done in the most efficient way with the minimum of disturbances (low vibration, low thermal dissipation...). A discussion presents the advantages of the selected solution.

Keywords: Cryogenic, Cooling, Telescope infrastructure

1. INTRODUCTION

A series of feasibility studies has been launched for the design of instruments which can cover most of the scientific cases. These studies have allowed identifying more precisely a coherent suite of instruments and its cryogenics need. These instruments have been distributed over the three main focal plane locations of the telescope. This is the starting point for the definition of the cryogenic infrastructure. Some extrapolations based on the VLT experience and the possible evolution of the science requirements have been assumed to guaranty covering the need beyond the first generation of instruments. The cooling requirements have been simplified limiting the number of discrete temperatures. Table 1 lists the temperatures which have been identified with the location where a supply is required.

Temperatures	Purpose	Power requirements	Locations (number) of duties		
			Nasmyth A	Nasmyth B	Coudé
230 K	Optical detectors	404 W	16	10	
105 K	NIR ins. optic	1579 W	3	28	1
65 K	NIR detectors	400 W	10	28	
27 K	MID IR optics	20 W		2	
5 K	MID IR detectors	35 W		2	

Table 1: Power requirements distribution

Most of these temperature requirements are directly based on long experience or direct dark current evaluations. The most discussable requirement is the one concerning the operating temperature of Near Infra-Red detectors. The past experience has shown various results which tend to confirm that some relaxation to higher temperature might be envisaged in a next future. Operating NIR detectors at higher temperature seems generally more to affect the cosmetics than the direct performance.

Economies of scale

A key driver for the E-ELT is the reduction of environmental impact through greater efficiency on the use of power etc. The Coefficient of Performance (COP) of a refrigeration system is defined as the ratio of the cooling power Q_c to the input power W . Developing the thermodynamics laws, we can determine the Carnot Coefficient of Performance (Carnot COP) which characterizes the best performance that a refrigerator can achieve. A paper was presented 40 years ago titled “Refrigeration for Superconducting and Cryogenic Systems”, T R Strobridge 1969. Figure 1 shows an update of the chart from this publication. It shows the “Percent of Carnot” which is the ratio of the real COP over the Carnot COP.

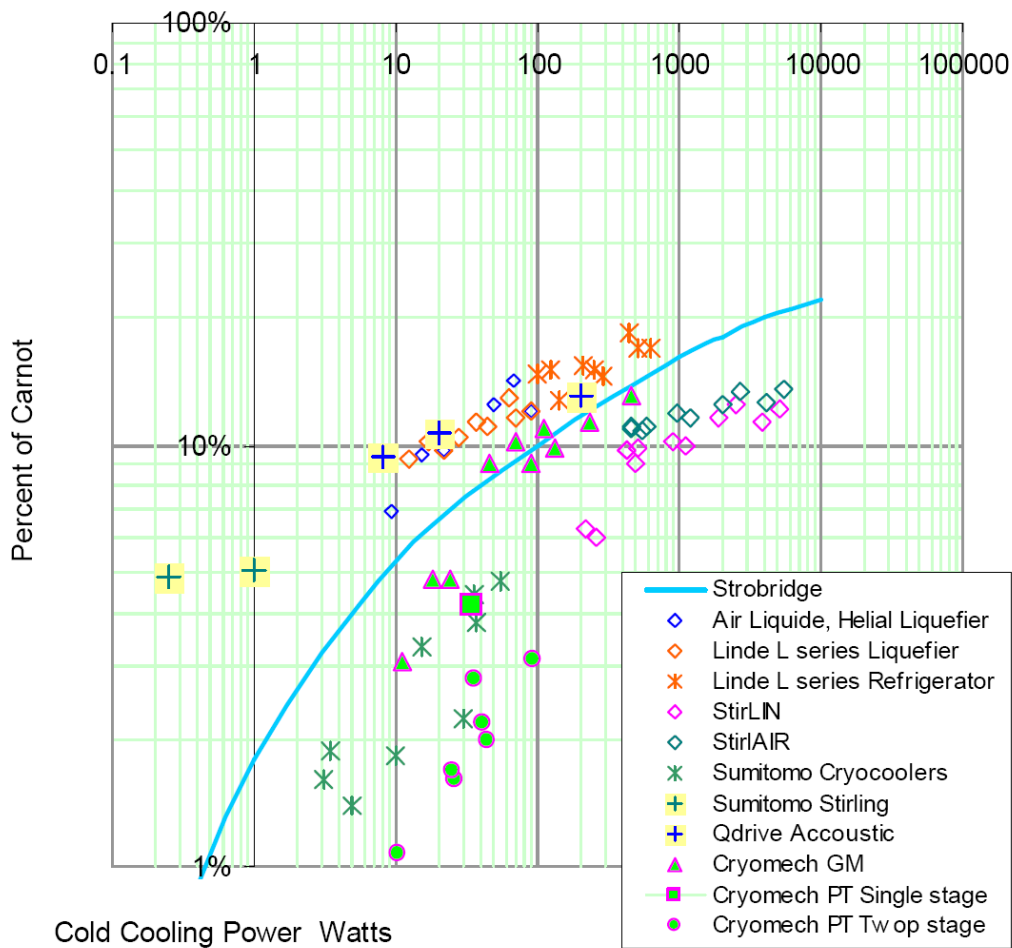

Figure 1: Strobridge plot "Percent of Carnot" -Modern equipment

For the purposes of this study it is noted that cryo-coolers have a cooling power in the range of 10 to 100 W. A centralized refrigerator will have an effective cooling power at 4 K of about 100 W. An examination of the graph above shows that the “Percent of Carnot” for a centralized refrigeration plant will be about 15% whereas it will be about 3% for individual cryo-coolers. (The notable exception is Stirling machines which, even as small units, will match a

centralized refrigeration plant). In very simple terms we can expect a five fold reduction in electricity consumption from a centralized refrigeration system for the same refrigeration power compared to GM and Pulse Tube cryo-coolers. Against a centralized refrigeration plant is the additional investment and heat losses associated with the vacuum insulated transfer lines to carry the helium cooling gas to each location. This will add between 50 and 100% to the cooling load. On the other hand it should also be recognized that each cryo-cooler is over designed for the discrete application. A centralized plant allows this contingency to be consolidated and therefore reduced. At the same time the management overhead and direct costs associated with maintenance of a centralized plant will be lower compared to multiple cryo-coolers. The ultimate economy of scale for a refrigeration plant at low temperatures may be the production of liquid nitrogen in a large scale air separation plant. In the chart above, such a plant run by the established industrial gas companies has an effective cooling capacity between 1 MW and 100 MW and therefore a “Percent of Carnot” between 40% and 60% (with 1969 technology). Therefore it is possible that liquid nitrogen, even allowing for transport costs (which roughly double the production cost), may provide an economic cooling solution.

2. DESIGN ANALYSIS

2.1 Mechanical coolers

This is, since the last decade, the conventional approach and therefore technologically proven for instrumentation of sizes and scales appropriate up to 8m class telescopes. Instrument builders and astronomical observatories are familiar with the technology. In general they consist of a ‘cold head’ where Helium gas is locally expanded to provide the cooling power. The cold heads are connected to a Helium distribution system which provides supply and return lines comprising a closed circuit to remote compressors.

There are three main types in use, Gifford McMahon, Sterling and pulse tubes. These generally take the form of an insert with a mating flange to the vacuum vessel. The insert extends into the vacuum vessel and may have up to three stages, which are progressively colder and of lower cooling power. The models with motorized mechanical displacers and valves can be a major source of vibration but some models allow remote motor operation or have pneumatic operation. The pulse tube cold heads are more likely to have no mechanical parts and as a result much reduced vibration and potentially longer service intervals. Pulse tube performance is more generally significantly affected by gravity orientation. Stirling Cycle coolers don’t usually go much below 77K.

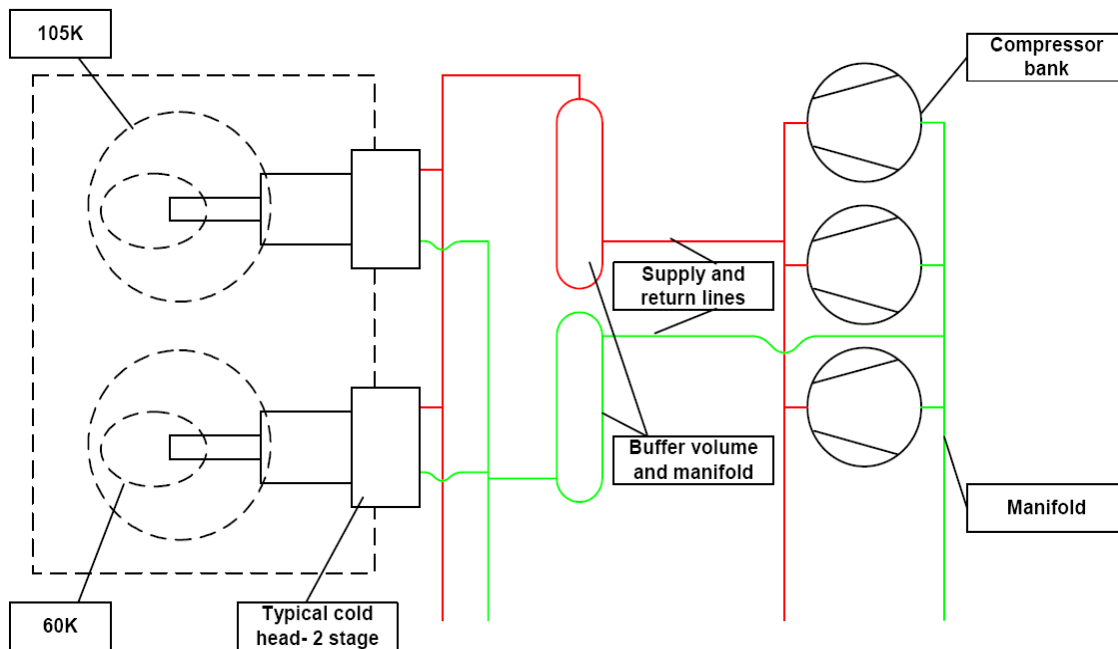

Figure 2: Schematic implementation of Mechanical Cooler

Figure 2 shows a possible schematic of the implementation of this solution. A bank of compressors, located in a remote building, is used to provide the high pressure helium to most of the cold head. It can be considered to have a separate system to supply the very sensitive 4K machines. A complex pressure monitoring system would have to be used to prevent mis-use of the system in case some component failures. Based on existing coolers system a number of 22 compressors would be required to power the 35 cold heads equipping on the potential first generation of instruments. This system offer a large flexibility, additional compressors could be added any time additional power is required.

The number and diameter of lines is the subject of detailed design which must include considerations of redundancy and continuous use through scheduled service as well as future expansion. At this stage and allowing for these considerations the infrastructure should plan for a minimum of 9 independent pairs of 32mm ID fixed lines running through the telescope. A global cross section of some 270 cm² will be required to fit the lines in the main azimuth cable wrap which should respect a minimal bend radius of 360 mm. Ideally, these lines will have sweep bends when negotiating corners. The building and telescope structure should allow for this. Manifolds are required at the compressor end and at the Azimuth and instrument wraps. At the instrument end, additional manifolds will be required to allow connection of multiple coolers.

The compressors and the cold heads are both significant sources of vibration. The cold heads historically have been more of a problem due to their proximity to the instrumentation and telescope structures. This can be addressed by selecting low vibration models. This can restrict the choice of cooler but hopefully manufacturers may be able to offer larger range of cold heads in the future. Due to the large number of cold heads, the vibration problem is likely to be worst on the E-ELT compare to existing facility due to the reliance in fast Adaptive Optics

The experience with smaller instrument has shows that it is not realistic to count on such system for the initial cool-down phases. Dedicated pre-cooling systems based on LN2 mass storage will have to be added.

An infrastructure based mainly on mechanical coolers might also be considered as rather sensitive to hazards. A simple power failure might ends with a horror scenario showing the complete battery of instruments worming up and loosing vacuum. Therefore provision must be made to guarantee the required reliability (redundancy of circuit and compressors).

Mechanical coolers being a common solution for instrument cooling, most of the potential instrument builders has a reasonable experience and training to implement this technology.

While the installation cost is well distributed over the various components (Compressor, cold head, tubing...), the operation cost is largely dominated by the cost of the electrical power. Even if the maintenance of the system required specialized manpower, it accounts for less than 25% of the running cost.

2.2 Closed loop Forced Convection with Helium gas

The cooling duties can be met using a closed loop refrigerator with helium as the working gas. The technology is common to helium liquefiers of which there are many hundreds installed around the world. The established suppliers are Linde and Air Liquide. A typical liquefier comprises a Kaeser compressor with an in-built water cooled heat exchanger, an oil removal system to clean the helium gas, a pressure control panel, a buffer tank to absorb volume variations in the helium gas inventory and a Cold Box. The latter unit converts the high pressure of the helium gas into low temperatures through a combination of heat exchangers and turbine expanders. There are still a number of options for this system. The system can provide gas at discrete temperatures for each duty and return the cold gas to the Cold Box so that the cold enthalpy can be recovered in the refrigeration cycle. This will minimize the refrigeration system size and the power consumption. However the penalty is an increased investment in vacuum insulated transfer lines and the heat losses associated with these lines. Alternatively the gas can be passed from the lowest temperature instrument to progressively warmer instruments. Ultimately the gas will be sent back to the refrigeration system possibly with no useful cooling to be recovered. The return line will still have to be insulated to prevent any low temperatures compromising the environment for the telescope. However there will not be the need for multiple pairs of transfer lines at the main operating temperatures. Another combination of options arises by a qualitative assessment of the cooling duties and a recognition that the coldest duties at 6 K and 30 K may best be served by cryo-coolers. The alternative is additional investment in increasing the capacity of the refrigeration system for a cooling duty which appears small but due to the low temperatures is a significant proportion of the total cooling duty.

Figure 3 shows the schematic implementation of the forced flow cooling system using a large refrigerator to cool helium before circulating it to the various instrument heat-exchangers.

The technology of the helium liquefier has been made reliable since the high cost of the smallest unit makes the investment to build in redundancy very high. For example many large scientific facilities operate with a single helium refrigerator even though this represents a Single Point of Failure. In reality some of the high costs reflect the high reliability which has been designed and built into these systems. However the requirements for the E-ELT are for high reliability with continuous availability. To meet these requirements two helium refrigerators will need to be installed. It is suggested that the cooling power is optimized at the most common normal cooling power. Since helium refrigerators have a small turn down before the operating efficiency is lost then this higher investment cost represents an opportunity to reduce the running cost. Therefore when the maximum cooling power is required both refrigerators will be operating. In normal conditions only one refrigerator will be operating. During refrigerator fault conditions and during schedule Maintenance, the cooling requirements will be constrained to the “mode average” operating condition so that it can be met with one refrigerator. Therefore the centralized plant will be designed around two refrigerators each rated at the “mode average” operating power. There will be a penalty in the equipment cost but the operating cost will be lower and the reliability will be higher. Unlike the mechanical coolers, contamination ought to be more easily controlled and the major failure mode concern would be a major leak or a power cut.

The vacuum insulated pipelines can be either single flow pipelines or shield pipelines (Multi-Channel Pipelines -MCL). The latter will use either helium at about 60 K or nitrogen to reduce the heat load on the low temperature helium. The length of the pipe runs between the plant room and instrument stations is approximately 290 meters. The pipe line has to have a flow and a return. Only MCL lines would guaranty the performance of the 6K duty; on the other hand the increase of cost is such that the use of mechanical cooler is clearly more economical. A global cross section of some 546 cm² will be required to fit the lines in the main azimuth cable wrap which should respect a minimal bend radius of 900mm.

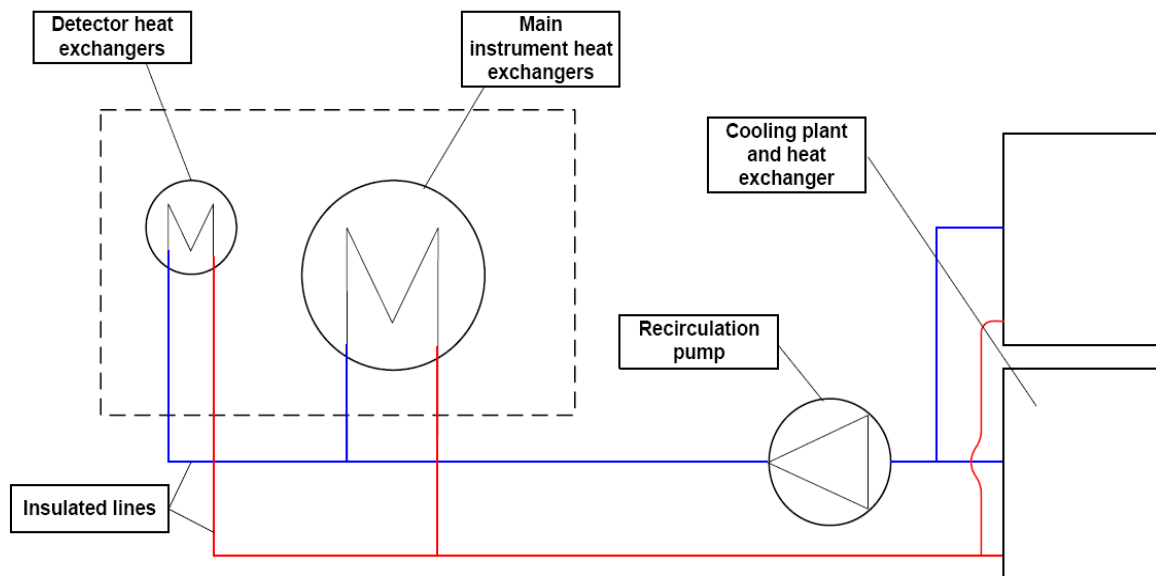

Figure 3: Schematic implementation of a forced flow cooling system

A dedicated pre-cooling system may not be needed, since distributed cooling can allow for a faster cooling.

Probably some developments would still be necessary in order to have this technology fully ready for our requirements. Heat exchangers would still need some optimization in order to get the highest heat transfer without causing any unwanted vibrations. This type of system can potentially have very low vibration but in order to achieve this, high flow velocities which are a significant fraction of the sonic velocity must be avoided. This would need some prototype work in any future design phase.

If the capital investment cost is clearly higher than for the previous mechanical coolers solution, the running cost, clearly dominated by the cost of the electrical power, is comparable.

This system has its largest impact on the instrument builders. Most of the ELT instruments will be build by consortia with the AIT phase located at different institutes over the complete European community. The use of such system would impose a duplication of cooling system at every AIT site with an enormous financial impact.

2.3 Open loop liquid nitrogen system

The open loop system will use liquid nitrogen to provide the cooling duties at the warmer temperatures of 80 K and above. The colder cooling duties at 27 K and below will be met by cryo-coolers. The cooling duties below 80 K will be obtained by reducing the boiling pressure. There are a number of options for the nitrogen system which are listed below:

For the nitrogen mass storage:

- ❖ The nitrogen could be delivered by a gas company resupplying a large bulk tank. The fill intervals can be of the order of a week.
- ❖ The nitrogen could be produced by a small liquefaction plant – the notable producer of such systems being Sterling Cryogenics & Refrigeration BV.

For the nitrogen distribution:

- ❖ The nitrogen can be distributed around the telescope using vacuum insulated transfer lines.
- ❖ The nitrogen can be decanted into dewars local to the users (focal stations) either by occasional use of a transfer line or moving the dewars to a fill station using a crane.

For the nitrogen exhaust:

- ❖ The nitrogen exhaust will be cold and will either require heating if it is vented near the telescope or it will have to be carried away from the telescope in vacuum insulated transfer lines.

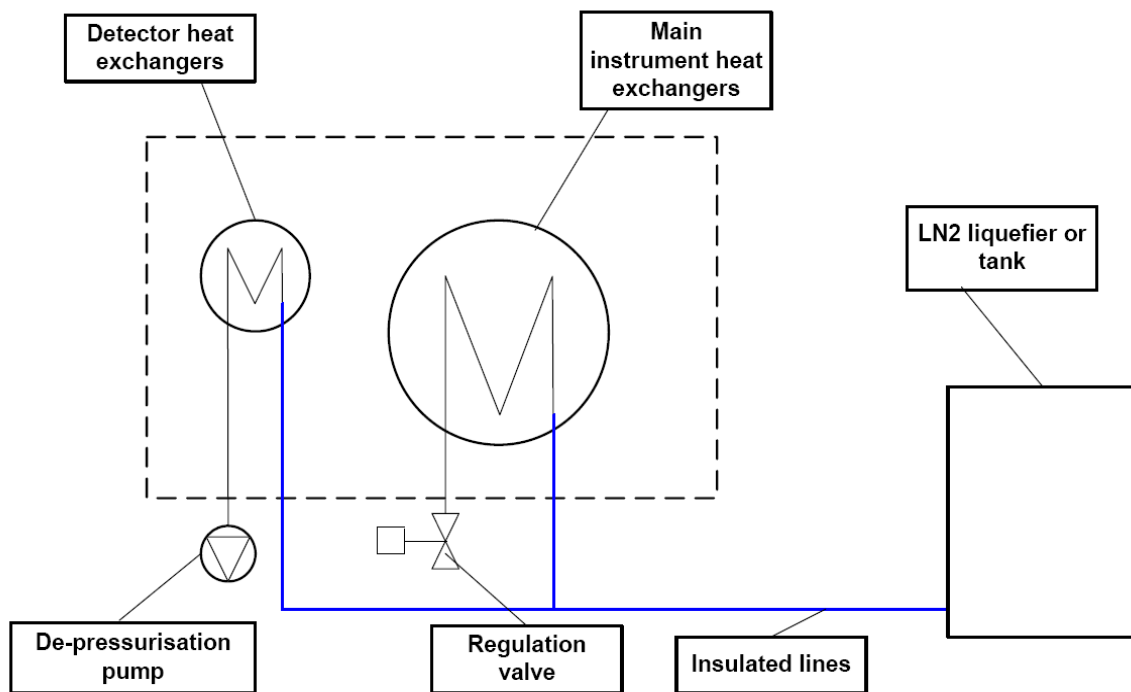

Figure 4: Schematic implementation of open loop LN2 cooling

Figure 4 shows the schematic implementation of an open loop liquid nitrogen cooling system. It shows the LN 2 supply and the vacuum insulating distribution lines which have to be installed on the telescope.

The instrument will require an insulated supply line which is a co-axial stainless flexible line with an over braid. The routing and strain relief of this line must be considered. In order to transfer the necessary amount of LN2 to the various focal stations a total of 8 lines would be required. A global cross section of some 160 cm² will be required to fit the lines in the main azimuth cable wrap which should respect a minimal bend radius of 700mm.

Figure 5 shows the influence of the altitude for the boiling temperature of liquid nitrogen. At an altitude of 2 500 meters the normal boiling temperature will be about 75 K and at 4 000 meters it will be 73.4 K. It is possible to pump on the liquid nitrogen and reduce the boiling pressure and therefore the temperature. However the lower limit is set by the freezing temperature of liquid nitrogen which is 63.2 K at 125 mbar.

The 65 K cooling duties are very close to the nitrogen freezing temperature of 63.5 K. However since the pumping stations can be in the close vicinity of the instrument it is possible that these duties are also amenable to liquid nitrogen cooling. Some additional development could be necessary to verify the feasibility of such system.

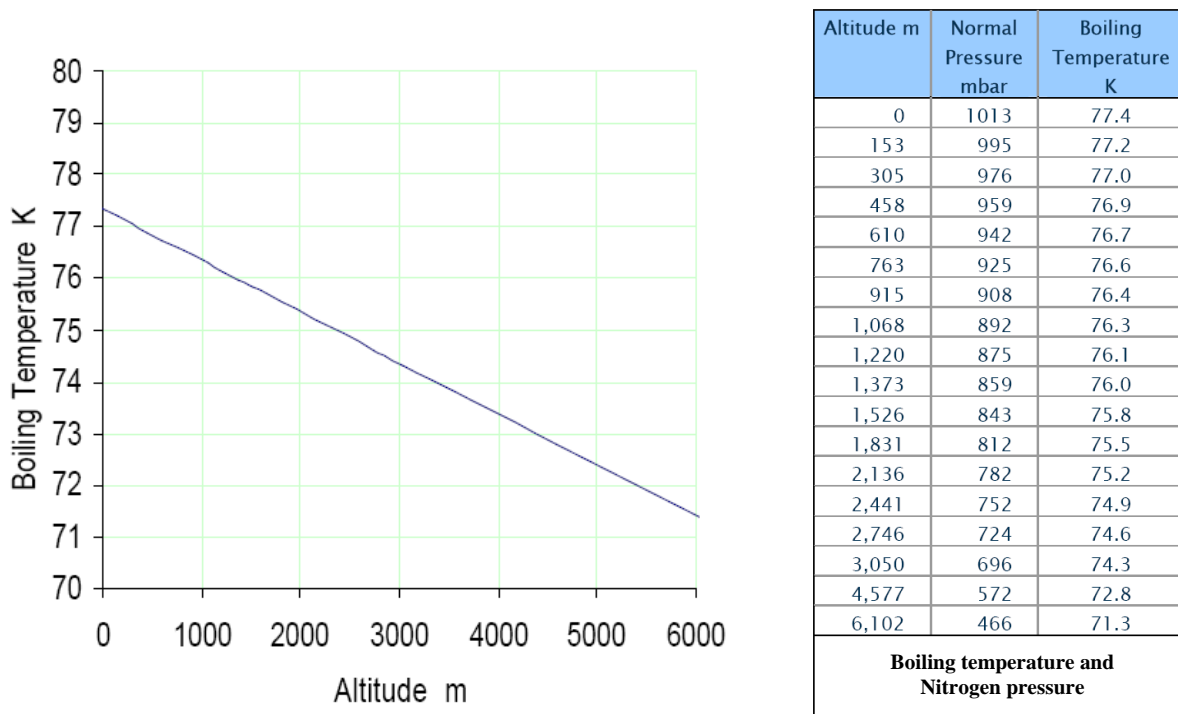

Figure 5: Boiling temperature of nitrogen at various altitudes

As explained above there is no way to reach temperature below 65 K. Therefore, like in the case of the previous solution using forced flow helium cooling, the cooling for the mid Infrared instrument will have to be provided by mechanical coolers.

Taking into account the long experience available at ESO, this technology can be applied (for the normal duties above 80 K) without any additional major development. In contrary to the two previous solutions this technology is less dependent on electrical power. Even if a solution with a local liquefier is selected, in case of problem, nitrogen can be bought on the local market. The same apply in case of serious damage of the supply lines the instrument could still be fed from a movable tank located on the Nasmyth platform.

Various options have to be considered to estimate the implementation of such technology. Actually independently from a solution where ESO produces the liquid nitrogen or it is procured on the local market, the operational cost are always dominated by the LN2 consumption which in a situation of full equipped telescope will amount to some 830 000 liters per year.

Some training and development of the instrument builders will be necessary to learn about this technology which has been widely abandoned during the last decade. On the other hand providing most of the specific components are made available, the cooling of instrument required very little infrastructure investment (only movable LN2 storage dewars).

3. COMPARISON

Table 2 shows the selection of trade off criteria which has been used to compare fairly the three technologies. Each has been allocated a weighting from 1 to 5, the higher the number, the more important the criterion.

The first assumption is that each solution has been designed to meet the requirements as summarized in Table 1. Each criterion is given a total of 10 points to allocate across the three solutions. Where the assessment is qualitative, the marks were: Best 5.5; Better 3.0; and Worst 1.5 though if it was hard to distinguish, an average such as “better + Worst” (2.25) was used. For a quantitative criterion such as installation cost, each concept is awarded a normalized score from a total of 10 points based on their values. Each score is then multiplied by the relevant weighting and totaled as per Table 3.

Criterion	Weighting	Comments
Telescope		
Vibrations	5	Contribution to the telescope random vibration environment
Running cost	2	Maintenance cost, consumables (Ln2..)
Power consumption	3	Simply electrical power
Capital cost	2	Cost of materials and efforts to set up the system
Installation efforts	2	Degree of difficulty in installing the infrastructure, especially pipe work
Technology readiness	4	Heritage of use in astronomy or related fields
Impact on telescope performance (dome seeing..)	3	To do with delta temperature on hardware and thermal dissipation.
Telescope services complexity	1	Space and minimum bend radii in service wrap
Reliability	4	Robustness, ease of maintenance (80% of the instruments 100% operation)
Failure mode tolerance	4	Number of instrument affected in failure and time for recovery
Scalability	3	Can the system start small and be scaled with time
Instrumentation		
Impact on instrument design and AIT	3	Combination of local control electronics, temperature gradients, complexity of heat transfer..
Instrument AIV support	3	Ease to emulate telescope system at instrument builder sites

Table 2: Selection of criterion

As we have seen in the preceding sections, each solution is reliant on some aspect of another to design a reasonably cost effective solution. The Mechanical Coolers need a fluid solution (probably Nitrogen) for fast pre-cool of these massive instruments while the Nitrogen system requires mechanical coolers below at best about 65K which could be a significant number of locations. The Helium solution could potentially provide cooling at all temperatures but was seen as being prohibitively expensive and complicated to use for the relatively small loadings below 60K where again mechanical coolers were preferred. Nevertheless, the trade-off indicates that the Liquid Nitrogen system is comfortably ahead of the Mechanical Coolers and Helium Gas closed loop systems, the latter two being hard to distinguish from each other.

This may be a surprise to those who have grown accustomed to mechanical coolers, but with the vast majority of the cooling requirements based around the 60K and 105K temperature ranges where Nitrogen is at its best and the significant increase in size of instrument, the economies of scale, additional flexibility in instrument design and failure tolerance are the main deciding factors. Also, when compared to other large cryogenic installations, liquid systems tend to be the norm.

Criterion	Weight (W)	Mechanical Coolers + LN2 pre-cool		Forced convection He + Mechanical Coolers		Open LN2 Cooling + Mechanical cooler	
		Score (S)	Mark (S*W)	Score (S)	Mark (S*W)	Score (S)	Mark (S*W)
Vibration	5	1.5	7.5	4.25	21.25	4.25	21.25
Running cost	2	2.4	4.8	4.5	9	3.1	6.2
Power consumption	3	2.8	8.4	4	12	3.2	9.6
Capital cost	2	5.8	11.6	1.4	2.8	2.8	5.6
Installation effort	2	5.5	11	2.25	4.5	2.25	4.5
Technology readiness	4	4.25	17	1.5	6	4.25	17
Dome seeing, tel. perf.	3	1.5	5.5	5.5	16.5	3	9
Telescope service	1	5.5	5.5	1.5	1.5	3	3
Reliability	4	3.33	13.32	3.33	13.32	3.33	13.32
Failure mode	4	1.5	6	3	12	5.5	22
Scalability	3	5.5	16.5	1.5	4.5	3	9
Impact on instrument	3	1.5	4.5	4.25	12.75	4.25	12.75
AIV support	3	3	9	1.5	6	5.5	16.5
TOTAL			120.62		122.12		149.5

Table 3: Trade-off marking

4. DESIGN PROPOSAL

The last section of this document presents a preliminary design of the ELT cryogenic facility. As the chosen concept departs slightly from usual technology, we also present a possible design of cooling system for an ELT instrument. A short discussion will highlight the necessary developments and the instrument construction strategy.

Figure 6 shows a sketch of the E-ELT enclosure with the routing of the various cryogenic supply lines. All lines start from the power plant where is located the liquefaction and storage of nitrogen and the helium compressors for the lower temperature duties. Depending on its final location, the laboratory where the new instrument are integrated and tested, could also be supplied by the telescope cryogenic infrastructure. The nitrogen lines to the telescope are grouped according the supply pressures. The lowest pressure is required to transfer the LN2 to the Coude room which is close to the ground level where is located the power plant. The highest pressure (~ 8 bar) is required to transfer the LN2 to the main Nasmyth foci, which are served by two lines each. A double pair (high pressure in and low pressure return) of Helium line will also be routed to the two Nasmyth platforms to provide the duties at temperature lower than 65K for the mid IR instruments. There are two Gravity Invariant Foci (GFI), which are located a few meters below the main Nasmyth. Dedicated lines operated at slightly lower pressure are distributing the nitrogen to these places. Another possibility is to have only one set of lines and intermediate storage tanks at every level. These tanks, which could be automatically refilled during the day, could have a considerable advantage on the regulation of the pressure.

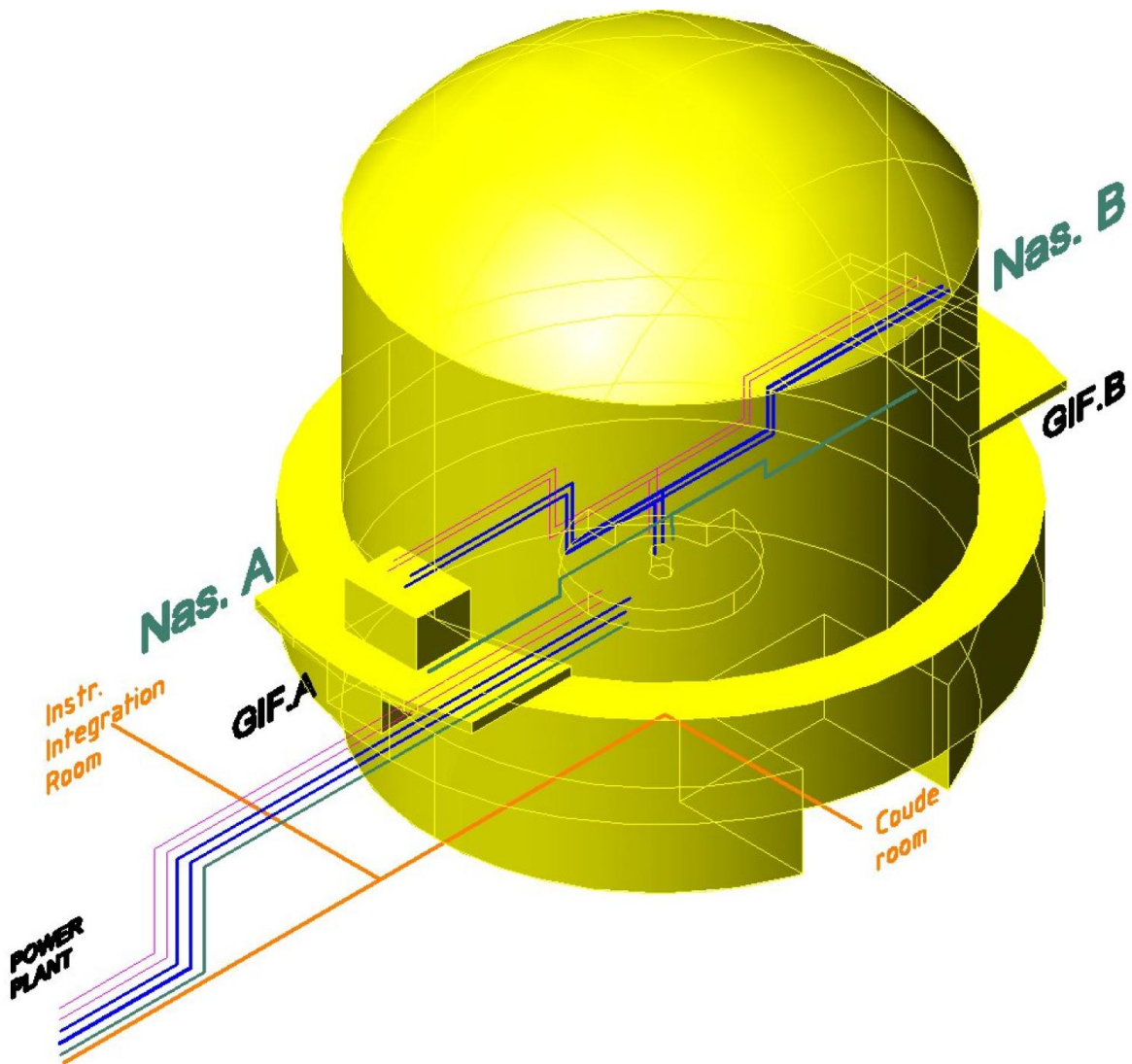

Figure 6: ELT Cryogenic facility

The helium lines do not wake any serious concern. This type of line is commercially available and some application has demonstrated that there is simple ways to reduce the impact of the extreme length on the performance of coolers. Long experience exists on the use of similar lines in cable wrap using much shorter radii of curvature. Concerning the distribution of LN2, a number of industrial companies have solid experience with construction of vacuum insulated line for the transfer of cryogenic fluid. There is less experience with this type of double wall line inside cable wrap. Different connection systems can be envisaged for the booting of the various sections of the line. The final selection will be subject to a careful analysis of the performance and reliability compare to specific requirements. A need of further development on this topic is not excluded.

Figure 7 shows a possible schematic for the cooling system of a standard E-ELT Near-Infrared Instrument. The cooling circuit has been divided into two main sub-circuits. The pre-cooling circuit, which is represented with black color, accounts a larger amount of heat exchangers on the core of the instrument. The regular circuit (shown in pink), which is used to keep the instrument at cryogenic temperature during operation, is using more heat exchangers on the radiation shield. The two systems can nevertheless share a common exhaust and regulation system (T1 control). The regulation is done using a valve controlled according to the temperature of a given point to regulate the flow of coolant circulating in the instrument.

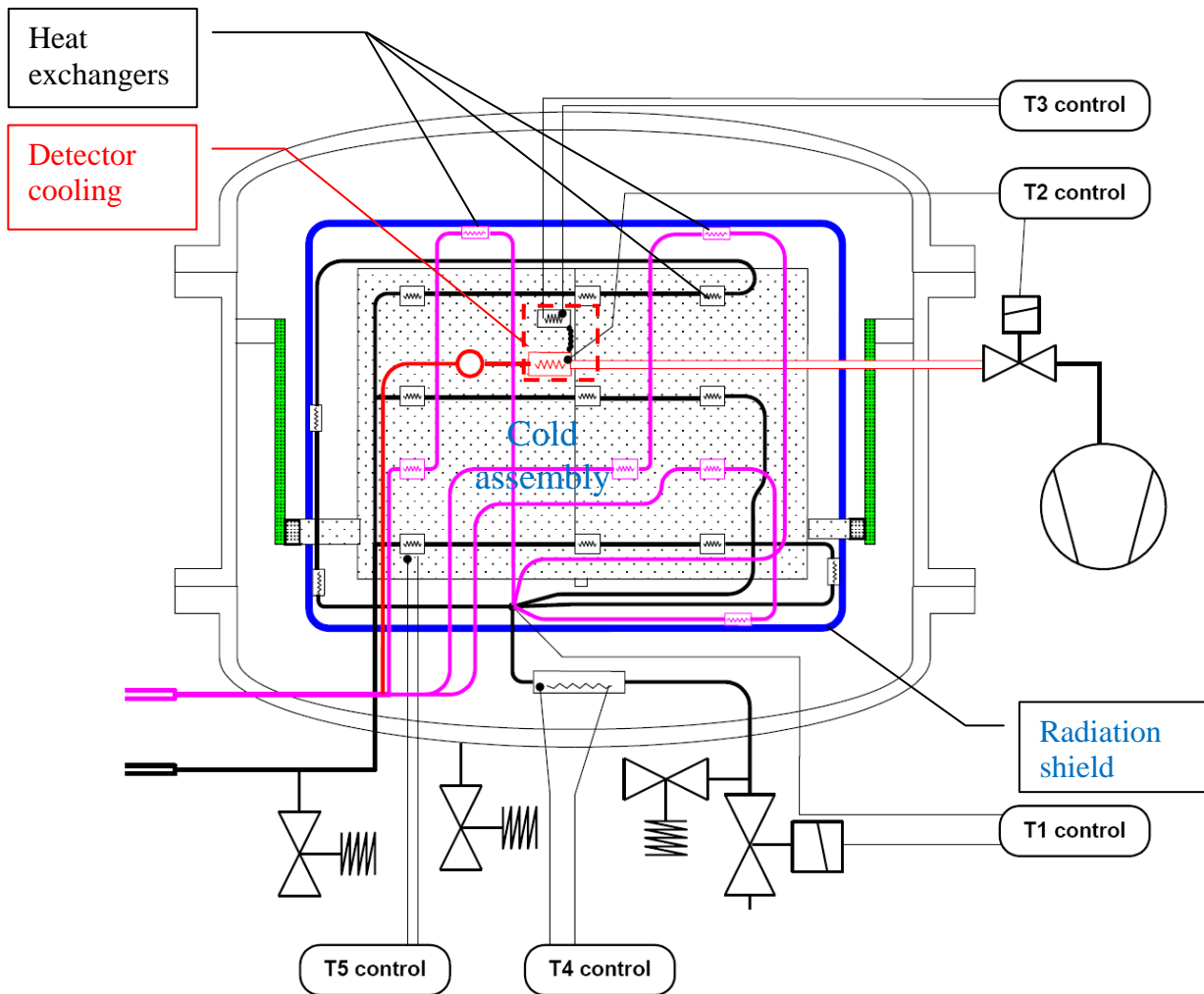

Figure 7: Cryogenic schematic of a Near Infrared ELT instrument

A number of additional control loops (exhaust gas heating (T4 control), instrument warm-up (T5 control)) are used to fully monitor the cryogenic process. The detector heat exchanger is supplied from the regular circuit. Like this, the cooling only starts when the instrument is already at cryogenic temperature. This will prevent any risk of detector contamination due to early cooling. In order to cool the detector to optimal operating temperature (65K), the detector will be cooled via a separated heat exchanger in which a pump is used to reduce the boiling pressure. There is no doubt that such principle works providing there is a high ratio of liquid in the heat exchanger. This condition is not always guaranteed in a continuous flow system. Therefore a phase separation will be necessary on the detector circuit manifold. This device acts also as a restriction at the beginning of this line and will allow a more efficient pumping. The system is operated very close to the freezing temperature of nitrogen. Some risk might be associated with this effect; therefore an additional loop (T2 control) is used to control the pressure in the heat exchanger acting on a valve. A last control loop (T3 control) is used to stabilize the detector in the micro Kelvin range.

Most of the E-ELT instruments will be built by consortia including research institutes of the European community. Not all these laboratories have the same level of experience and knowledge of the cryogenics. Therefore they will be guided and supported during the design and construction phase. One of the main supports will be provided by a cryogenic solution catalog from which the various components (LN2 inlet, Heat exchangers, Circuit splitters..) could be selected and ordered. This will also offer a certain level of reliability and guaranteed standardization. The completion of this catalog will be one of the main goals of the coming year together with the final design of the infrastructure.

ACKNOWLEDGEMENTS

This study was part funded by the European Union Framework 7 Programme under the auspices of the Preparatory Phase study for the European Extremely Large Telescope.

REFERENCES

1. <http://www.eso.org/sci/facilities/develop/integration/>