

THE VLT ADAPTIVE OPTICS FACILITY

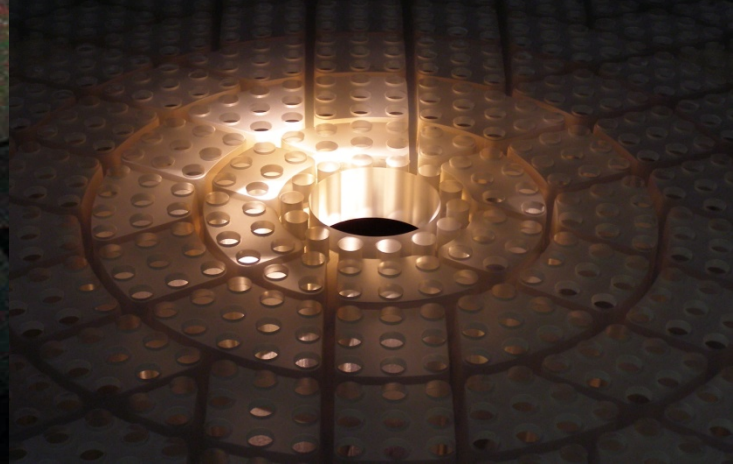

SUMMARY:

AOF Overview

The DSM: the core of the AOF

DSM Positioning System and Manufacturing

DSM Reference Body

Mirror Unit manufacturing

DSM Thin Shell

TOPTICA-MPB 20 W Laser Concept

Launch Telescope System

GALACSI: AO Module for MUSE

GALACSI Design

MUSE Spectrograph

GRAAL: GLAO Module for HAWK-I

GRAAL Design and Performances

GRAAL Assembly

ASSIST: DSM Testbed

ASSIST Design

WFS Detectors and Electronics

SPARTA: Standard Platform for Adaptive Optics Real Time Applications

Milestones

Organization Chart

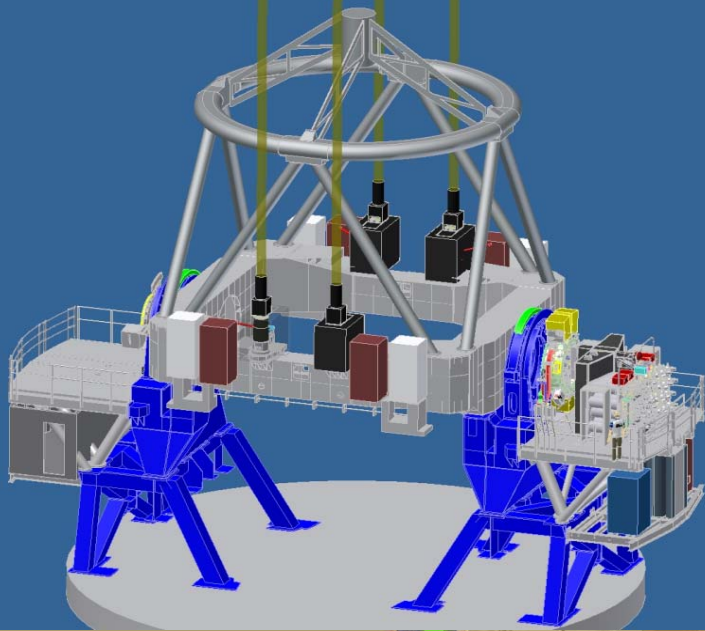

- AOF: ADAPTIVE OPTICS FACILITY:
- DSM: DEFORMABLE SECONDARY MIRROR
- 4 LGSF: 4 LASER GUIDE STAR FACILITY
- GALACSI: Ground Atmospheric Layer Adaptive Corrector for Spectroscopic Imaging
- MUSE: Multi-Unit Spectroscopic Explorer
- GRAAL: GRound layer Adaptive optics Assisted by Lasers
- HAWK-I: High Acuity, Wide field K-band Imaging
- ASSIST: Adaptive Secondary Simulator and Instrument Testbed
- SPARTA: Standard Platform for Adaptive optics Real Time Applications

OVERVIEW

AOF

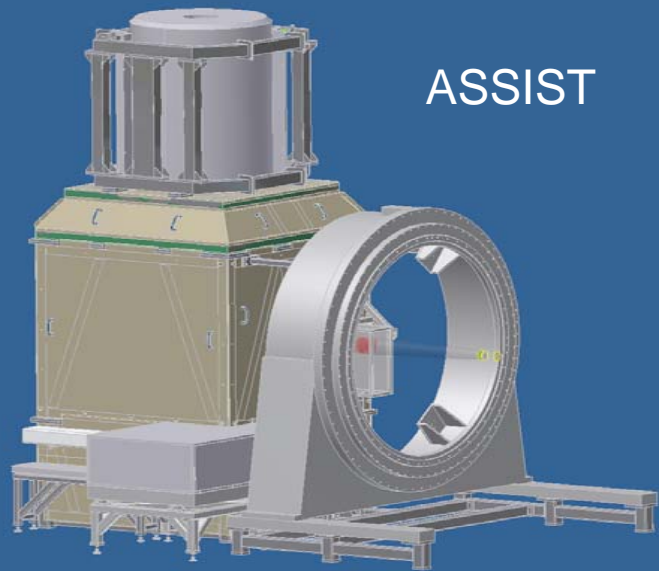

ASSIST

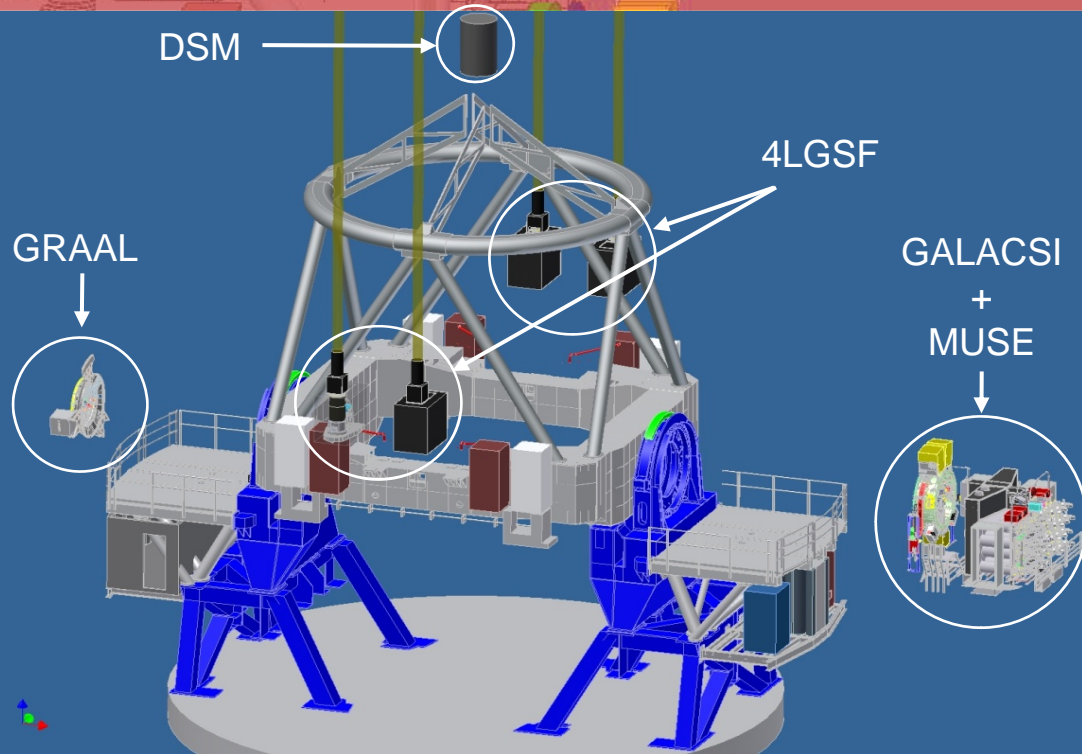

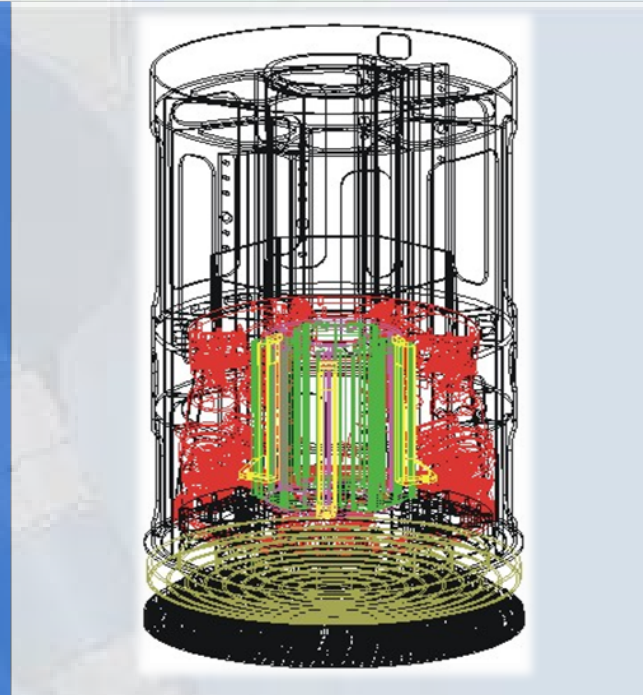
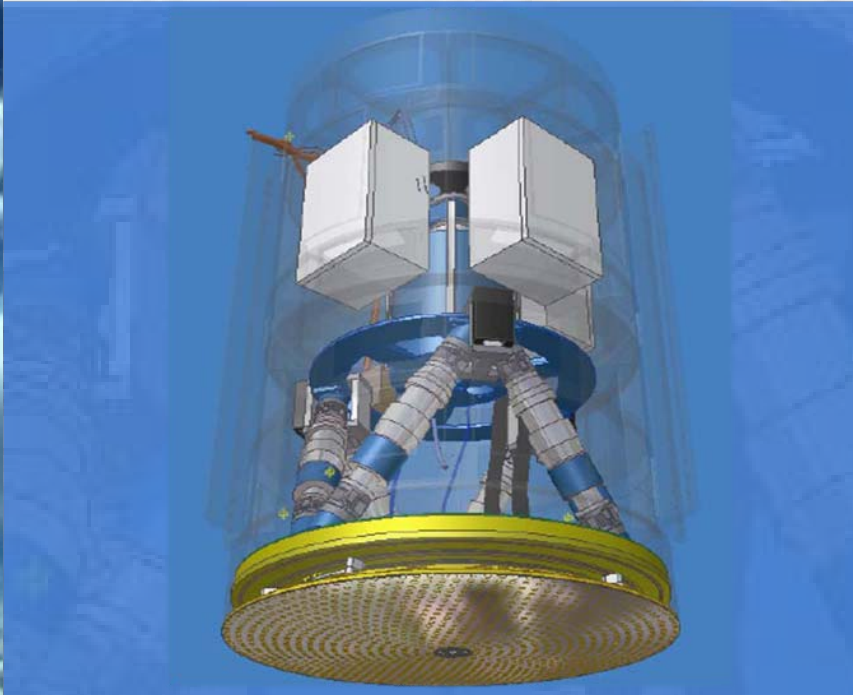

THE DSM: THE CORE OF AOF

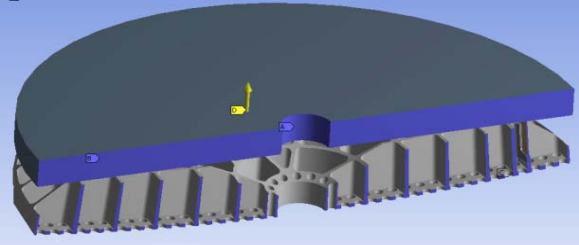

The cold-plate plus the back-plate.

M2 unit is composed by an hexapod, a cold plate, a backplate and a thin shell mirror. The mirror positioning is obtained with an hexapod. The actuators are attached to a cold plate connected to a reference body, on which the thin shell is leaning when not operative.

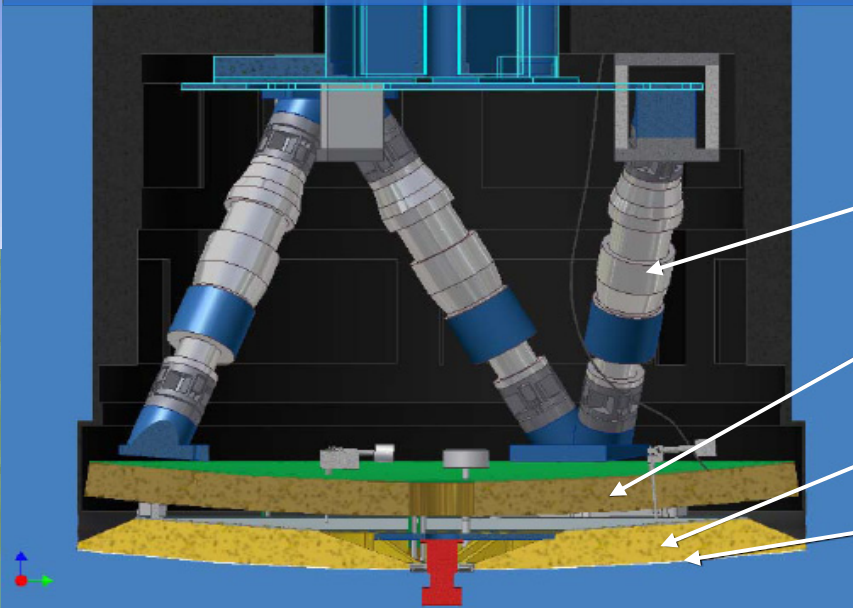

Hexapod for centering and fine focusing

Cold Plate, heat evacuation and actuator attachment

Reference body

Thin Shell

The thin shell mirror has a diameter of 1120 mm, 2 mm thickness, about 9 kg weight. 1170 voice-coil actuators are acting on magnets glued on the back face of the shell (below: actuators pattern).



HUB
manufacturing
on going.

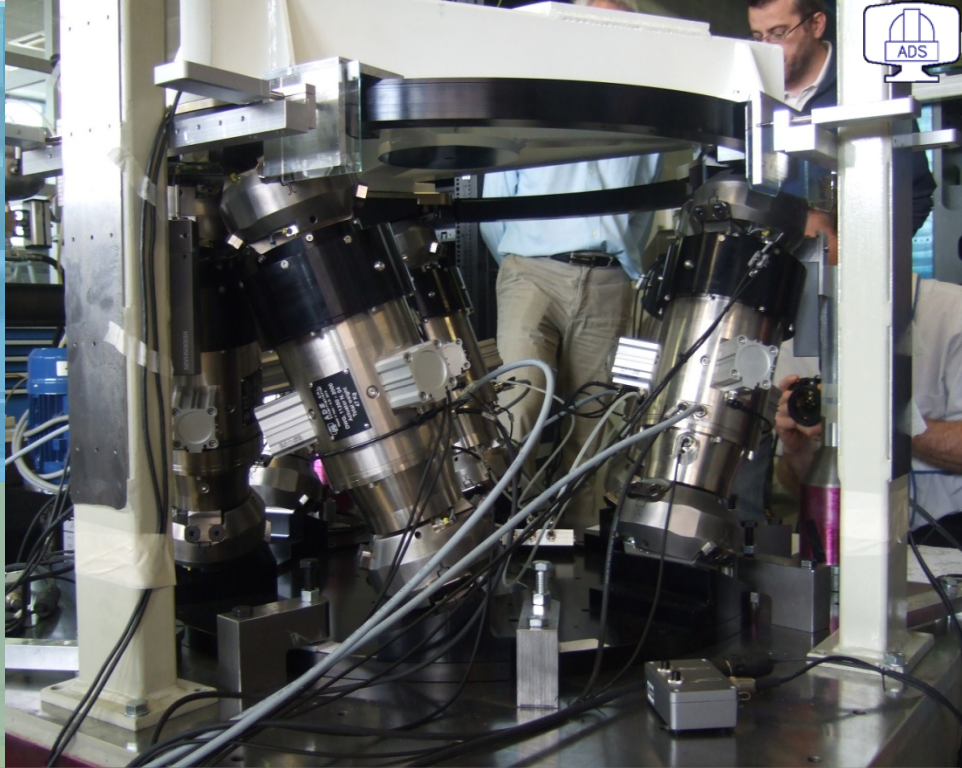

DSM POSITIONING SYSTEM MANUFACTURING

Complete
verification,
including full load
test in the final
configuration, of
all the hexapods
at ADS (May
2011)

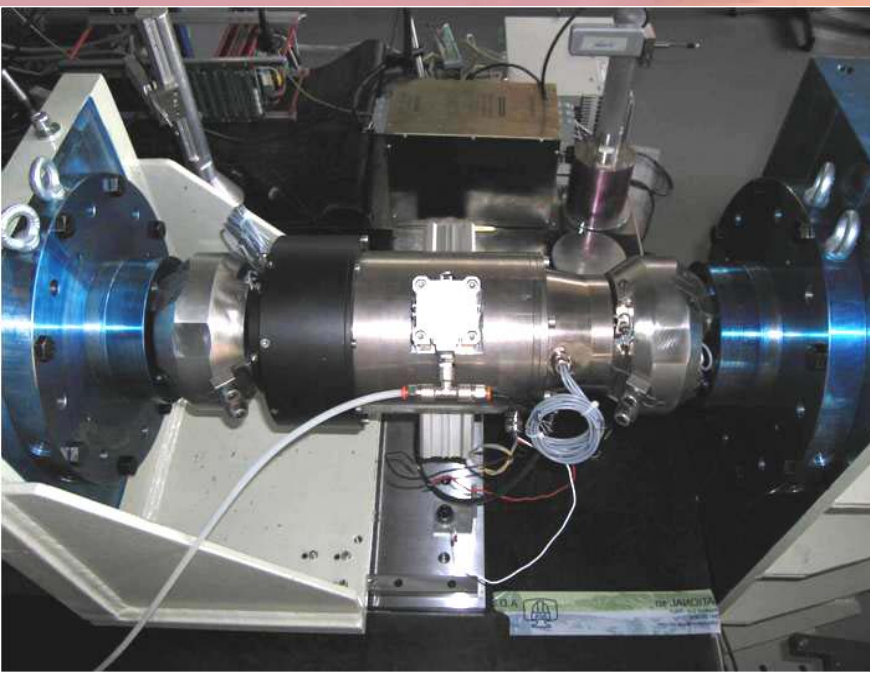

Hexapod
actuator
prototype
during
functional
test

Complete
verification,
including full load
test in the final
configuration, of
all the hexapods
at ADS (May
2011)

All the
Hexapod after
manufacturing
and functional
testing at
ADS (March
2011).





The magnets template manufactured at ADS, for very accurate gluing of the magnets on the back face of the thin shell.

The cold plate has been manufactured and metrologically checked with a computer controlled machine at ADS. It supports the 1170 magnetic actuators, provides a heat sink for the heat dissipated on the actuators coils and makes a mechanical interface for the backplate..



DSM BACKPLATE AND ACTUATORS

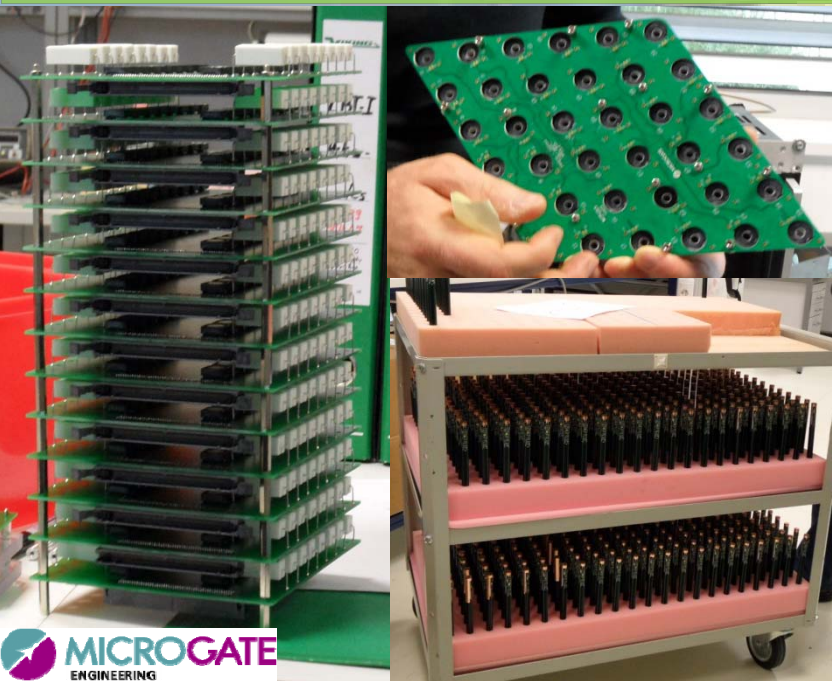

Right: "mass" production of electronics and actuators at Microgate..

Below: D-45 prototype test with and without thin shell: Electronics test, actuator coil test, capacitive sensor test.

The thin shell is retained at its central hole by a dedicated titanium and steel bound (membrane), designed in order to prevent only lateral displacement, without affecting the magnetic actuator action.

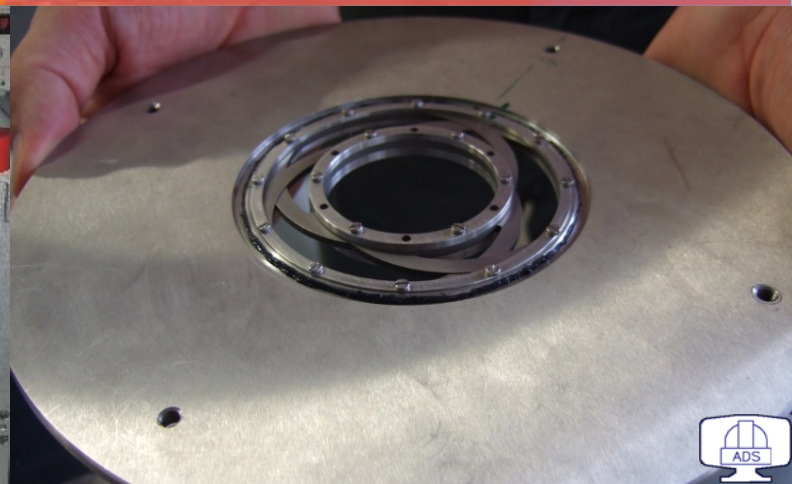

Detail of the DSM ZERODUR light weighted reference body back side at the end of manufacturing at SESO (August 2010).



The reference body at ADS, after silver coating and capacitive sensors etching (March 2011). The total weight of the component is 47 kg.

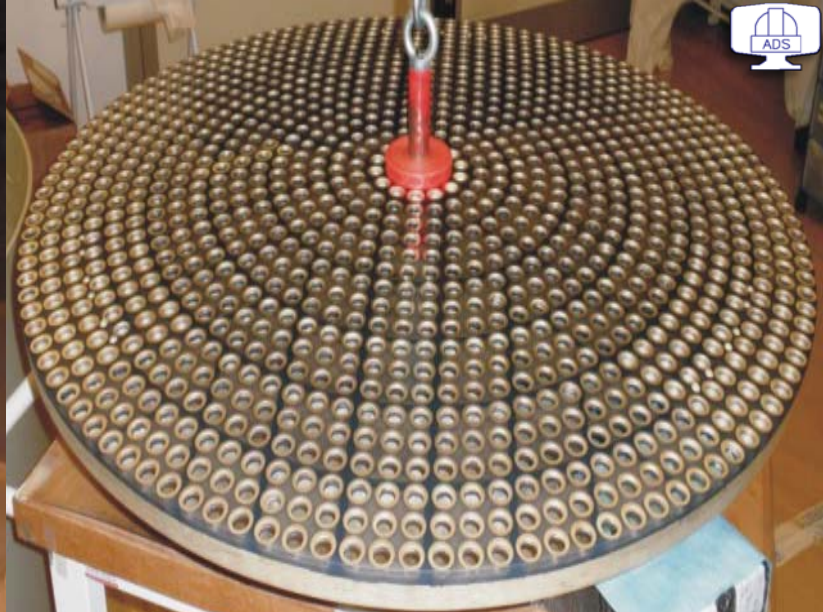

REFERENCE BODY

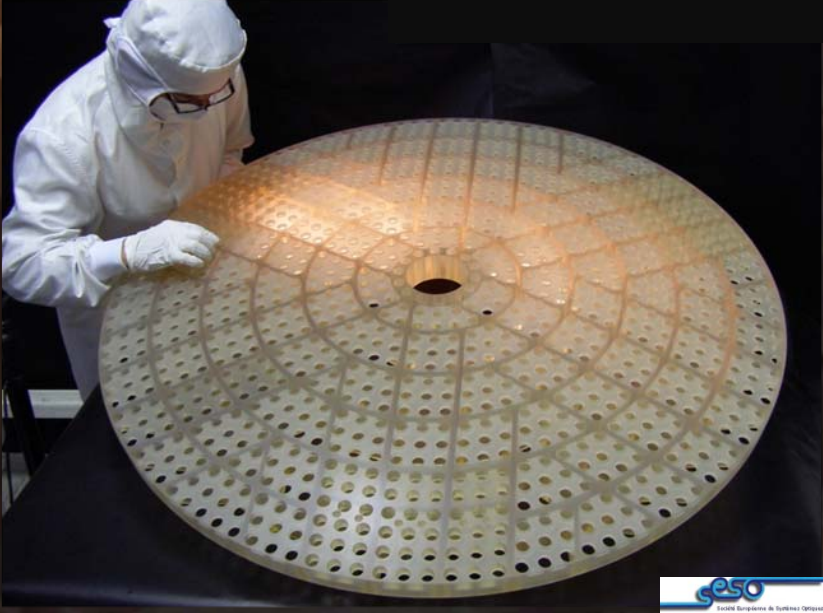
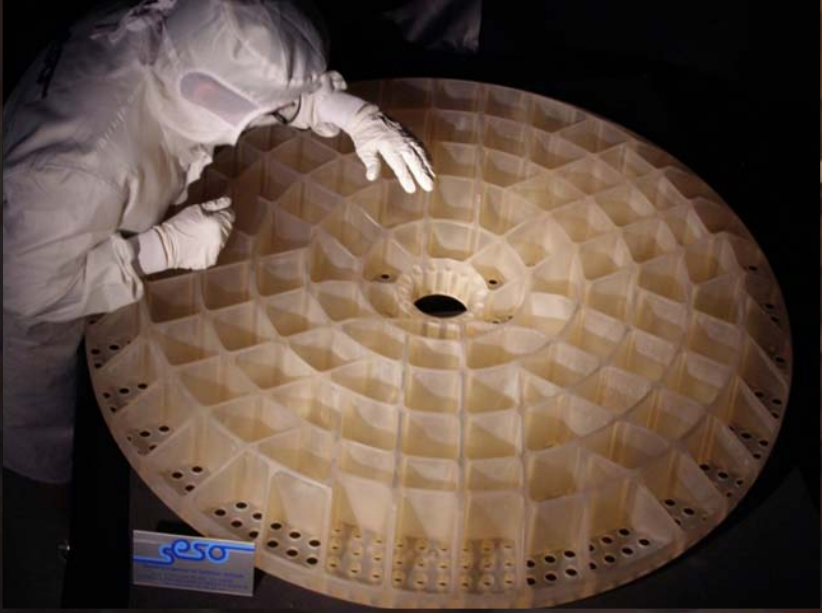

Final inspection of the reference body at SESO. The unit is ready for the metal coating deposition on the internal sides of the holes, for the capacitive sensor.



The M2 Zerodur Test Matrix produced by REOSC for the VLT, inside the barrel (mount) manufactured for the M2 Test matrix by AOF. The test matrix is being inserted into the barrel with a custom designed and fabricated handling tool (April 2007).

Hextec slumped engineering shell, to be used for electromechal testing of the M2-DSM unit.

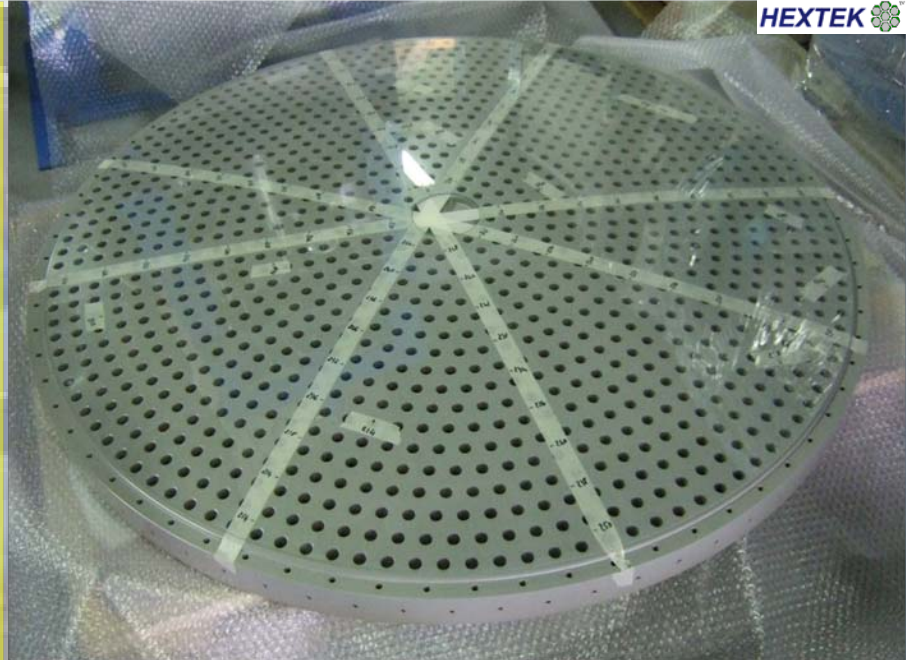

DSM THIN SHELL

Hextec slumped engineering shell
Schott blank for SAGEM (first science shell)



Left: first thin science shell during the final phase of the convex side polishing at SAGEM (inspection, February 2010). The Zerodur blank (Schott) grinding started in December 2009. In February 2011 the thickness was about 2.8 mm.

Right: The thin shell in February 2011 at SAGEM. In March 2011 the goal thickness of 2 mm has been reached: it's the first time in Europe for a curved shell.



TOPTICA-MPB 20 W LASER CONCEPT

The TOPTICA-MPB design converts the infrared light generated by two coherently combined Raman Fiber Amplifiers into the yellow spectral region by Second Harmonic Generation (SHG): two 18 W beams at 1178 nm are combined with Coherent Beam Combination (CBC) for 20 W beam generation at 589 nm. With this approach more than 20W at 589 nm are achieved.

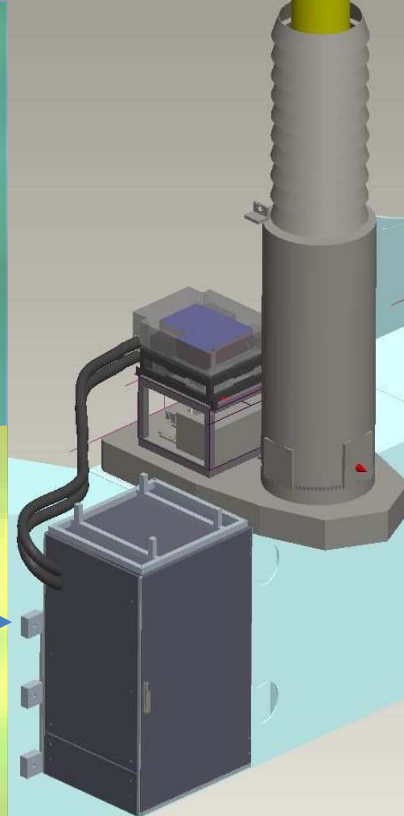
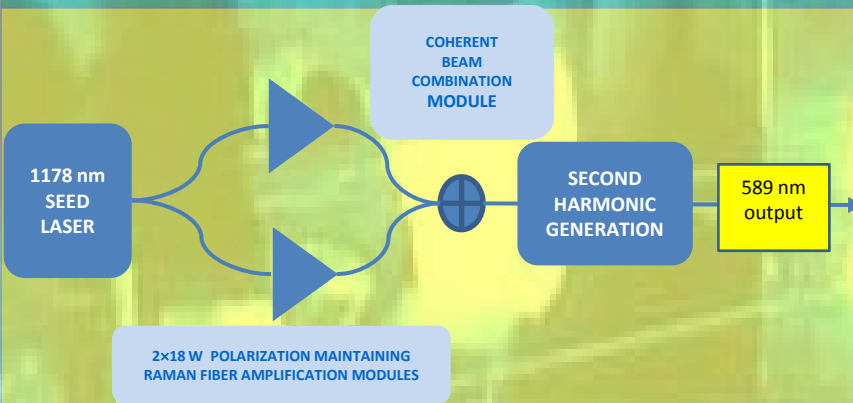

The TOPTICA-MPB design source is very compact, and will be located next to the launching telescope, without the need of a dedicated clean room.

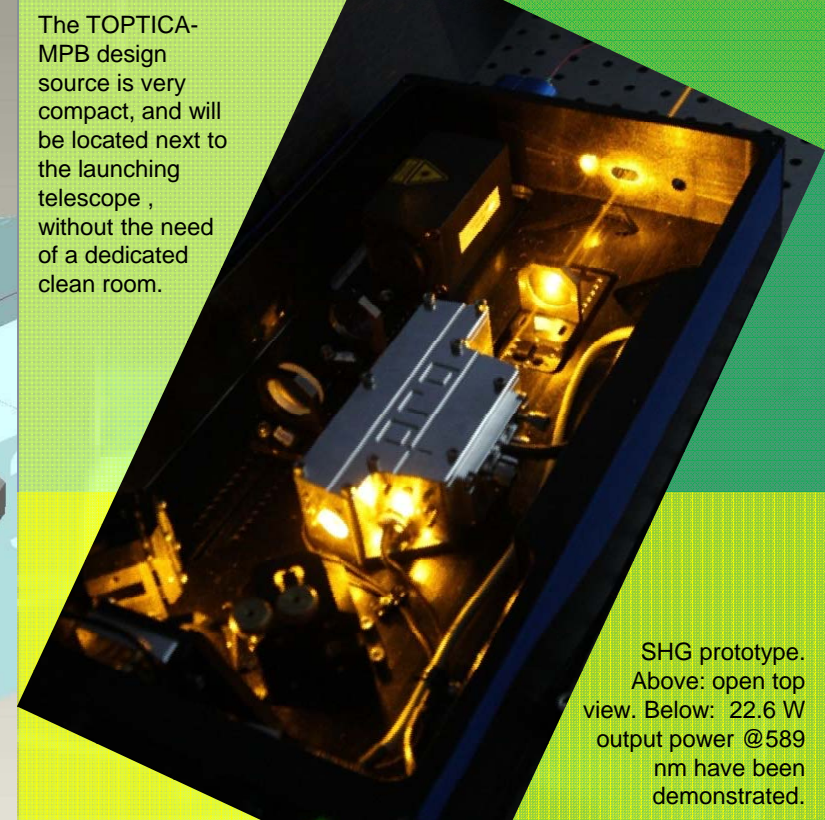

SHG prototype. Above: open top view. Below: 22.6 W output power @589 nm have been demonstrated.

589nm power vs. input 1178nm power

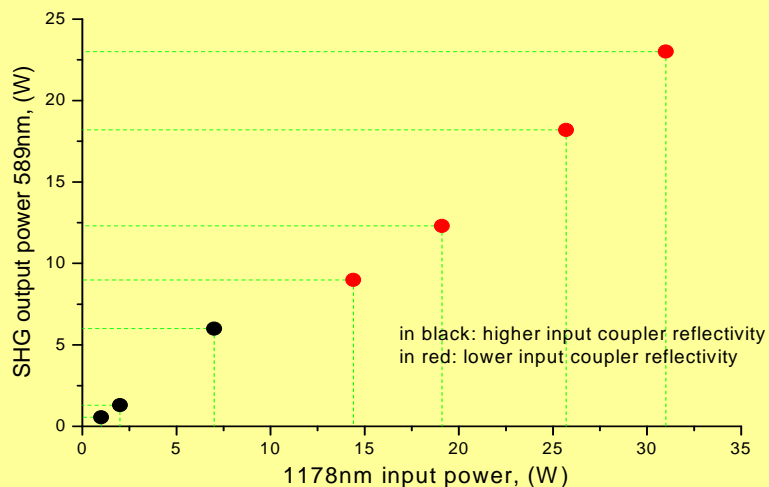

The laser design is being developed by TOPTICA and MPB as part of the ESO LGSF laser system. TOPTICA concept is based on Raman Fiber Amplification (RFAM). Left: plot of the output power @589 nm, as a function of the total RFAM power.



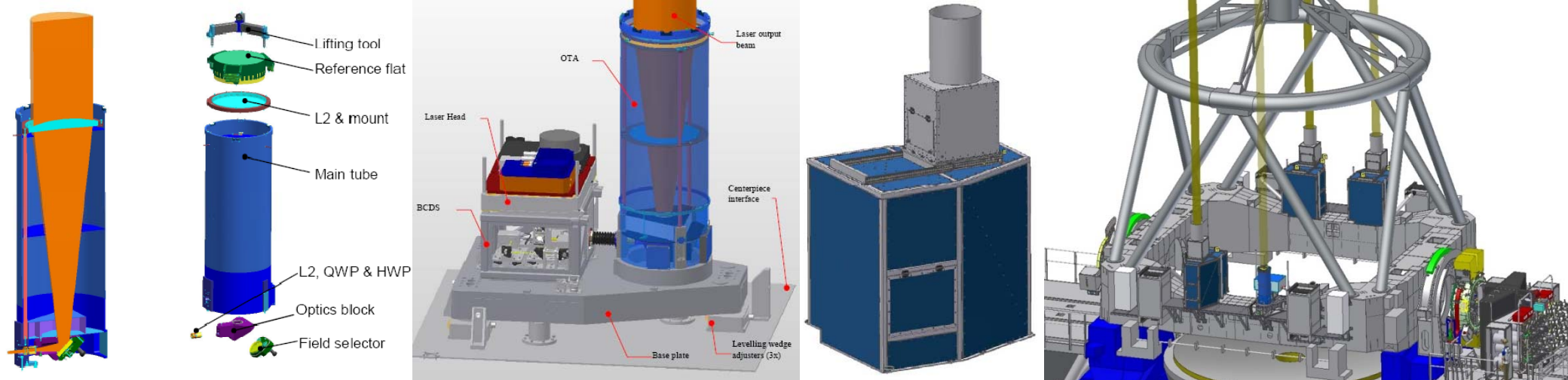

LAUNCH TELESCOPE SYSTEM

Above, from left to right: scheme of the optical tube assembly; 3-D model of entire LTS, including Laser Head, Beam Control Diagnostic System (BCSD), Optical Tube Assembly, on its base plate; the LTS inside its enclosure; the four LTS units on the telescope.



Below: the OTA structure at the end of manufacturing at TNO (January 2011).

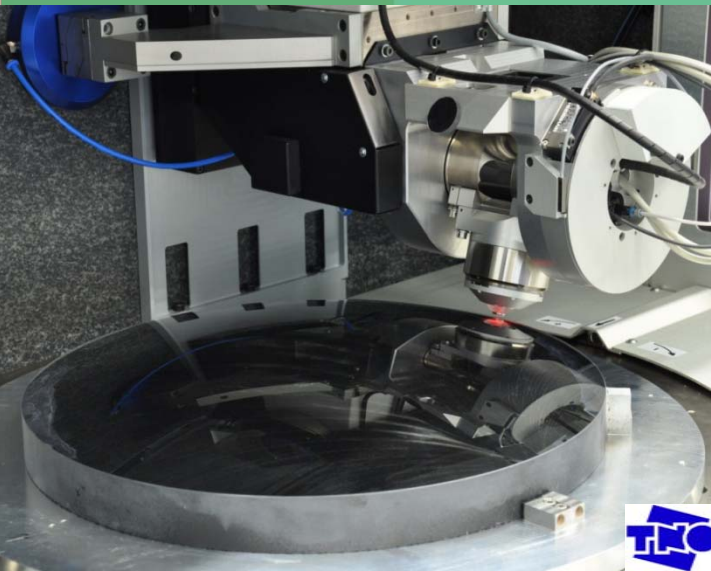

Above: testing of coating samples at focus under high laser power illumination (March 2010)

The LTS optical system is designed in order to expand the 3 mm diameter 589 nm wavelength laser beam to a larger beam producing a laser spot of about 30 cm at 90 km height. Four of these units will be mounted on the telescope azimuthal platform, in order to create the 4 LGS.

The main OTA L2 during manufacturing at TNO (January 2011). L2 is a 50 mm thick, 300 mm diameter aspherical lens.



GALACSI goal is to concentrate the energy of a Point Spread Function (PSF) over a large FoV (1') for a visible-light integral field spectrograph (MUSE: Multi Unit Spectrographic Explorer), a second generation instrument for VLT.

Here: 3-D model of GALACSI (left) on the Nasmyth platform with MUSE (right).

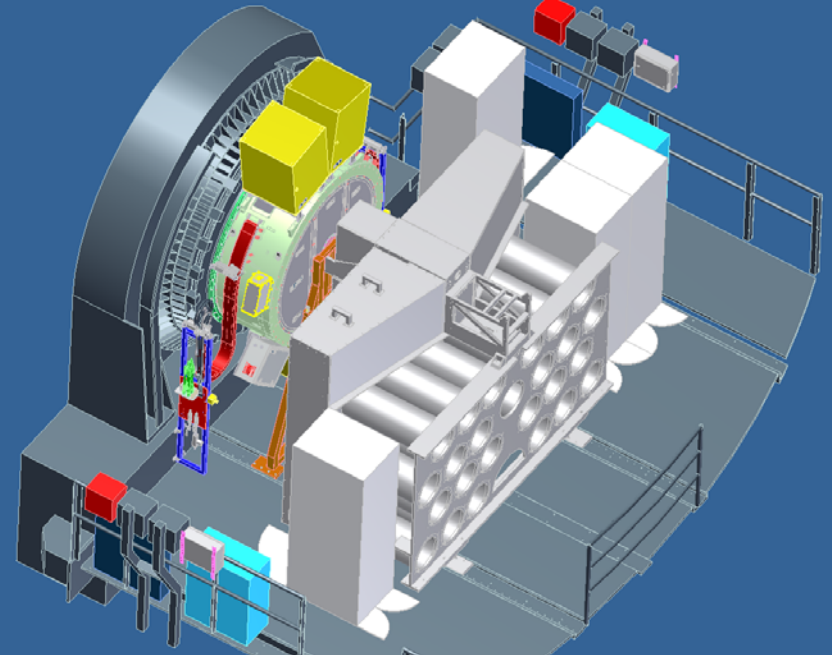

Field of view	1' WFM (7.5" NFM)
Instrument	Muse (VIS 3D-spectrograph)
Modes	GLAO, LTAO
Performance GLAO	×2 in ensquared energy (central pixel), 95% sky coverage
Performance LTAO	Strehl Ratio >5% @0.65μm
WFS	4 LGS L3-CCD (1 e ⁻ Read out Noise) 1 TT L3-CCD 1 TT IR
Loop frequency	= 1 kHz
SPARTA	HW=GRAAL
4LGSF	4 stars Ø2'/Ø20" LTAO drives LGS power
ASSIST	Full FoV
Status	FDR passed

GALACSI: AO MODULE FOR MUSE

GALACSI will operate in two modes: Wide Field Mode (WFM, seeing reducer over 1' FoV at 750 nm) and Narrow Field Mode (NFM, SR ≅ 6% at 650 nm, in 7.5" FoV). Here is shown a typical simulation of the PSF as expected with GALACSI in NFM.

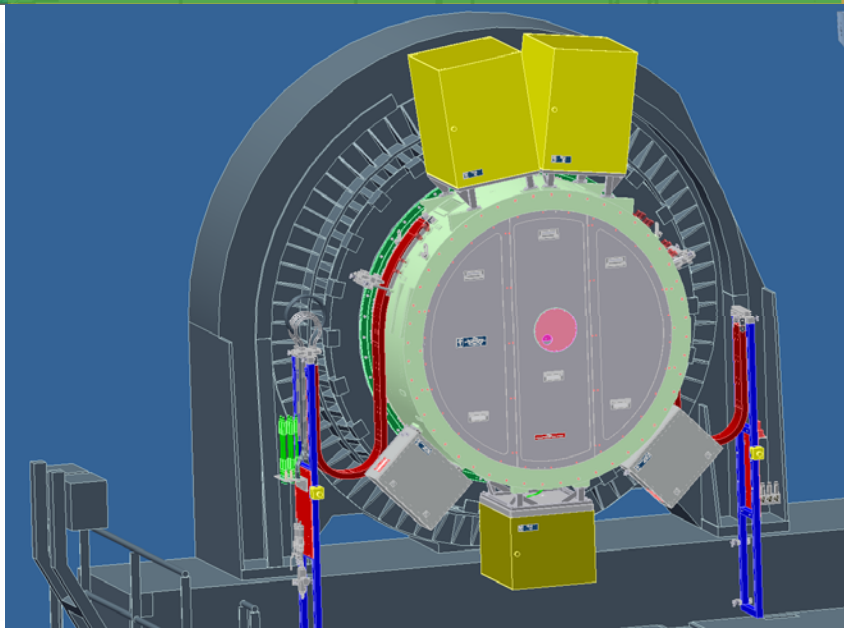
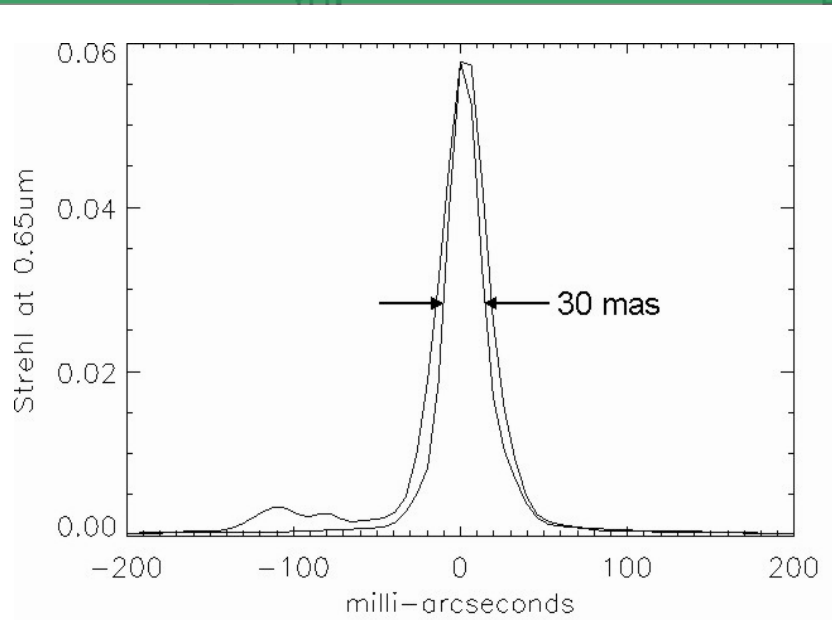

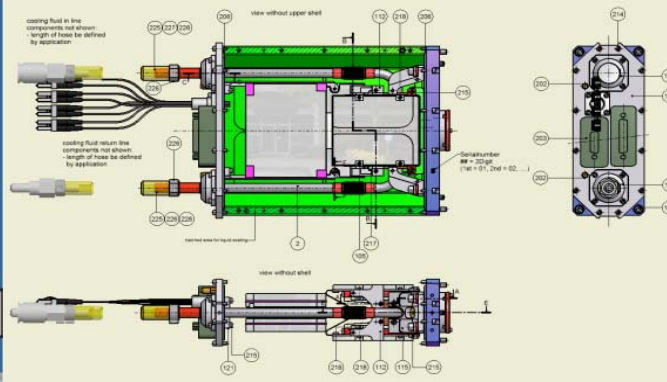
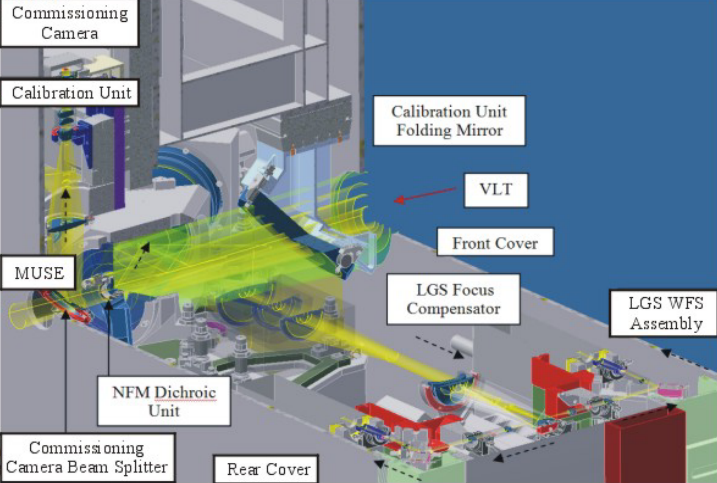

Left: 3D GALACSI optical scheme, as view from MUSE.

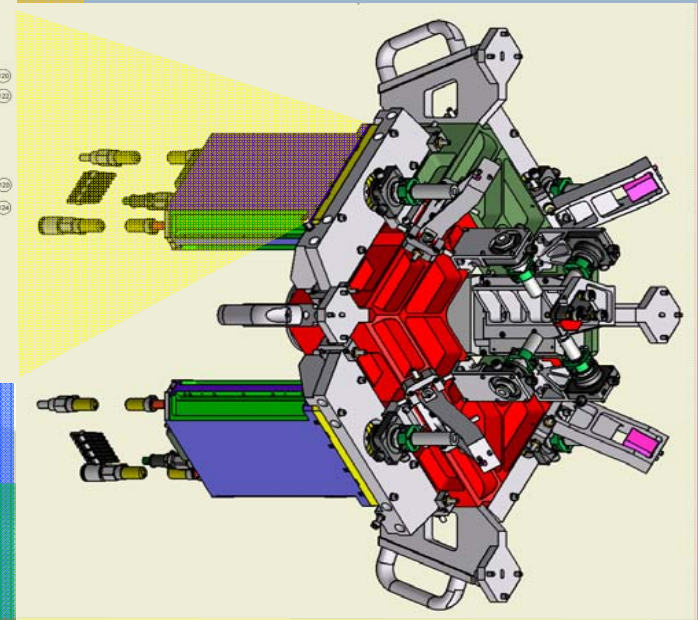

Above: the camera is the same as for GRAAL. Right: WFS detector and electronics.

GALACSI DESIGN

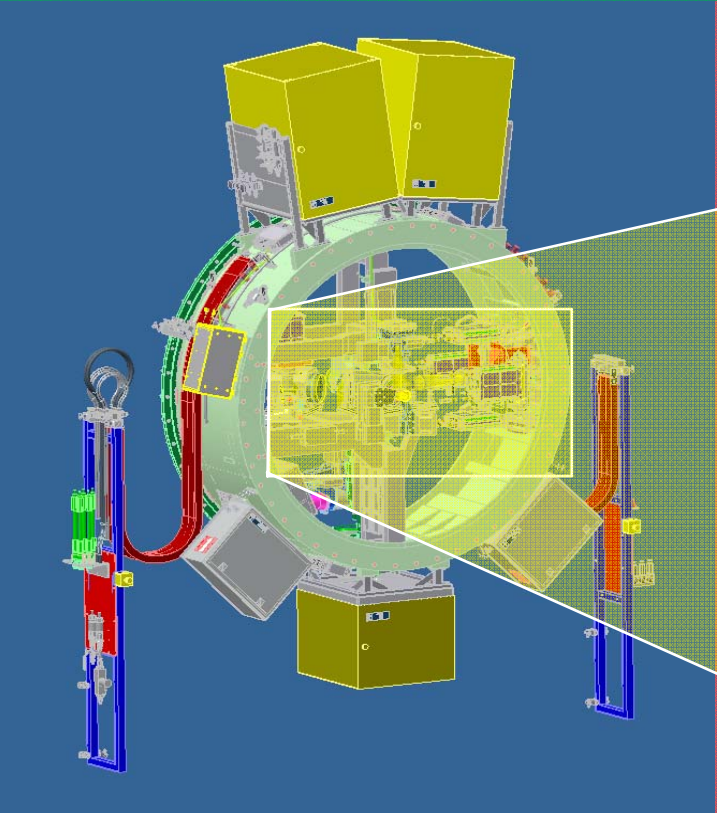

Left: 3-D opto-mechanical design of GALACSI: the LGS path module is shown in more detail enlarged above on the right.

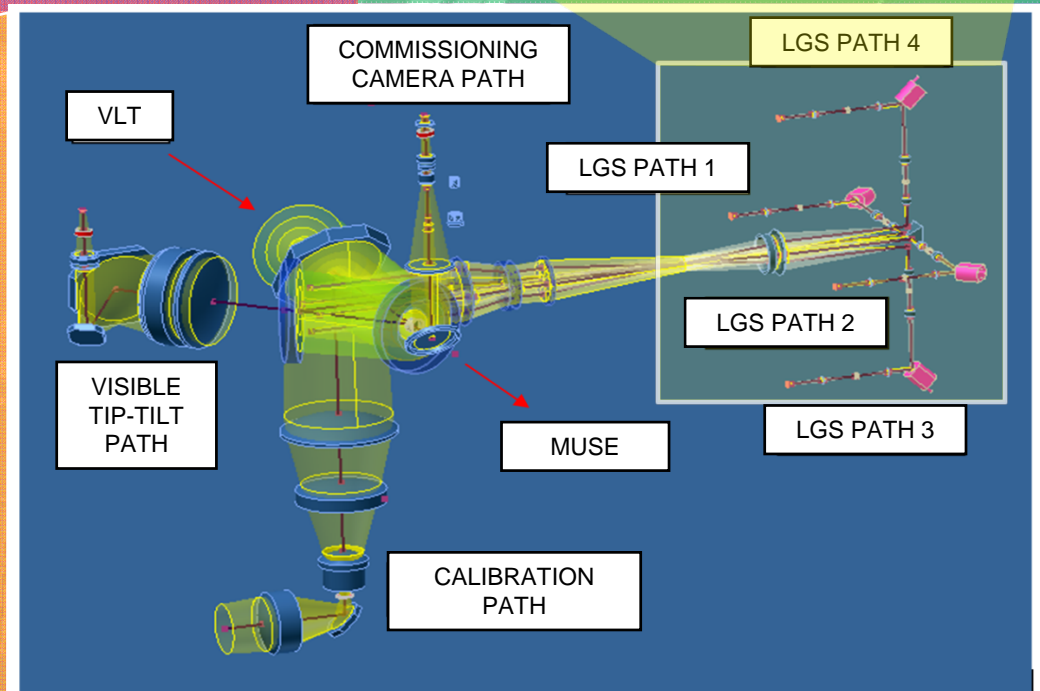

Left: 3-D opto-mechanical design of GALACSI: the LGS path module is shown in more detail enlarged above on the right.



Below: the the GALACSI support structure at ESO (March 2011) being aligned.

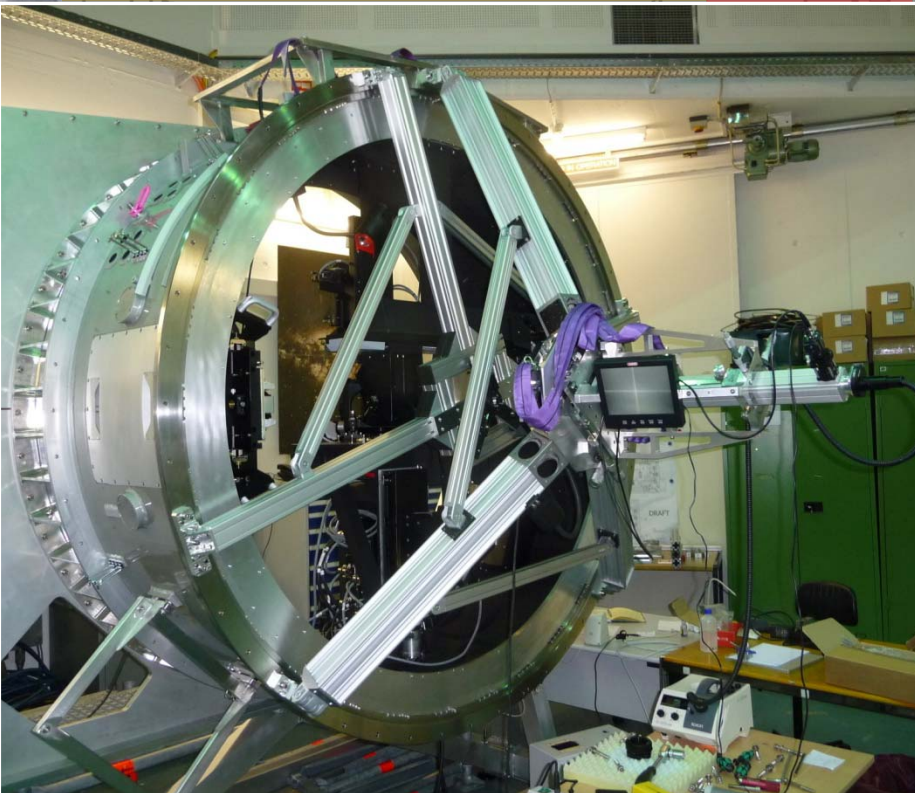

Above: the GALACSI Field Selector on a test setup: the Field Selector, source module, Lamp housing/fibre injection and motor controllers are in use.

Above: GALACSI almost completely assembled, during testing at ESO. Except the LGS wavefront measuring path, GALACSI is already equipped with all the optics.

GALACSI

GROWTH

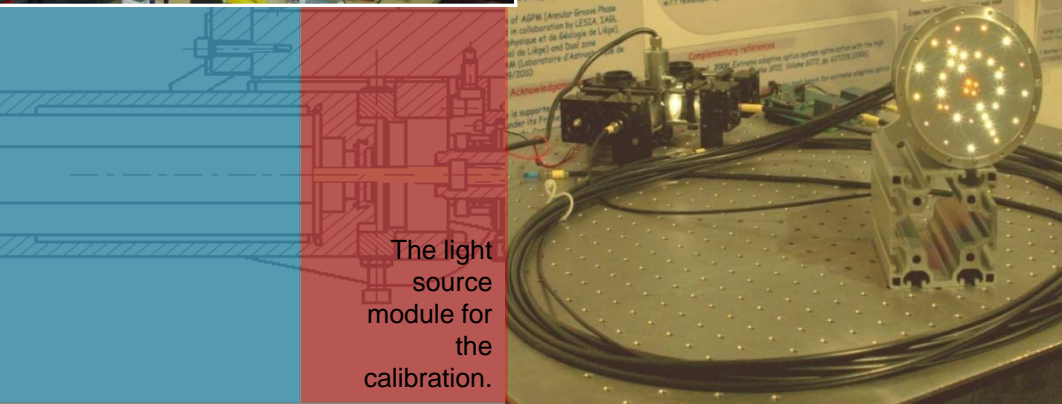
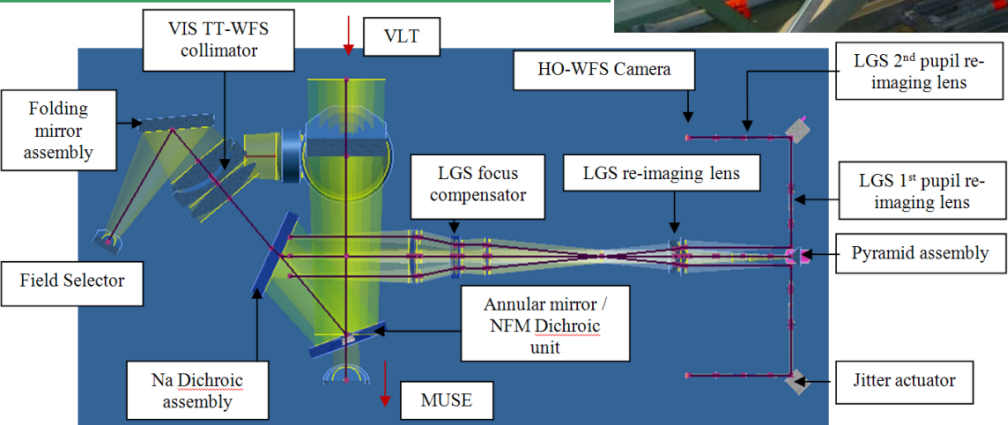

The light source module for the calibration.

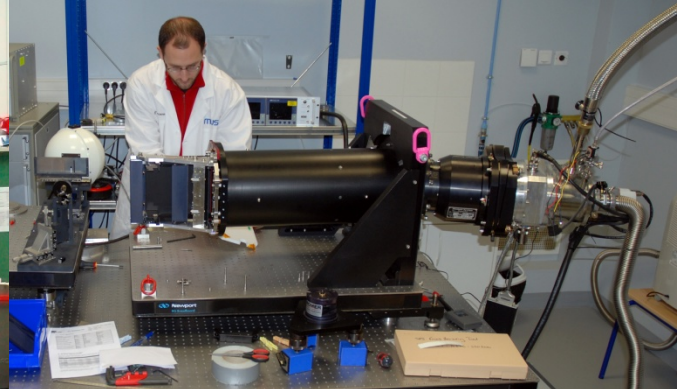
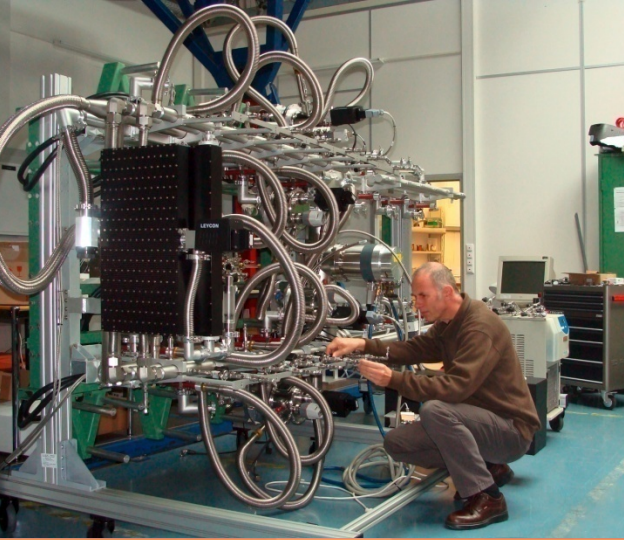
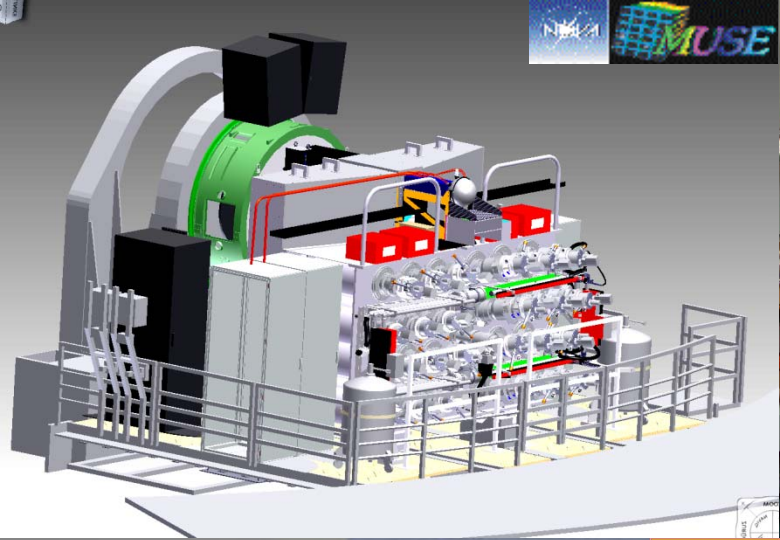

Above: the first of the 3D spectrographs, ready after extensive testing at the CRAL optical laboratory.
 Left: the large MUSE cryogenic system which provides cooling and vacuum for the 24 MUSE detectors (-130° C), in the integration and test phase at ESO

MUSE SPECTROGRAPH

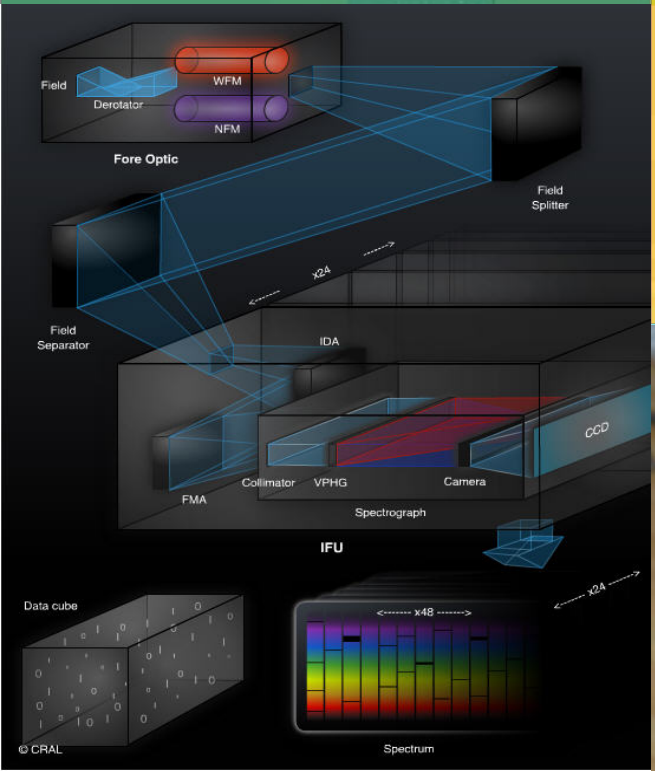

MUSE visible integral field spectrograph splits the GALACSI adaptive optics corrected field of view in 24 sub-fields. Each of these sub-fields is fed into a spectrograph (Integral Field Unit, IFU). An image slicer in front of each IFU serves as entrance slit, thus producing a spatially resolved spectrum of the full sub-field.

MUSE features a Wide Field Mode (WFM) with a 1×1 arcmin field of view and a Narrow Field Mode (NFM) with a 7.5×7.5 arcsec field of view, providing simultaneous spectra of numerous adjacent regions in the sky. A fore-optics tower between the telescope focus and the IFUs hosts a field de-rotator, an ADC, the shutter, the field splitting optics and a plate scale changer. A calibration unit is close to the telescope focus. MUSE total weight is more than 7 tons.

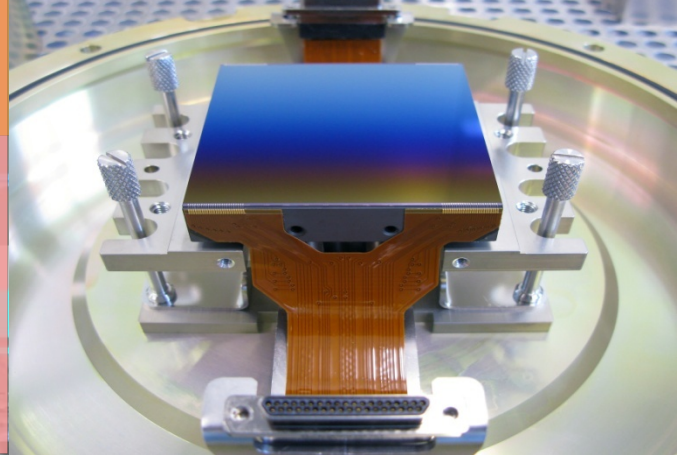

Above: one of the 24 16-million pixel detectors to be used in MUSE. MUSE combines 24 spectrographs (460-930 nm wavelength) in order to be able to probe a field of view as large as possible.

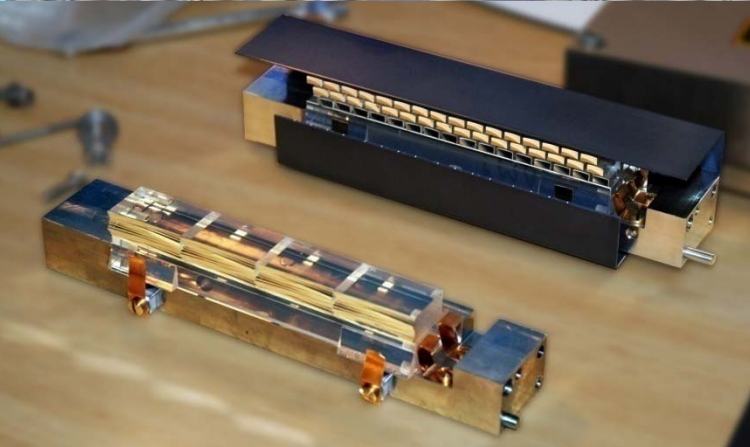

Left: an image slicer, composed of two optical elements: the image dissector array (in front) is made of 48 thin (0.9 mm) off-axis spherical mirrors and the focusing mirror array is made of 48 round off-axis spherical mirrors. Image slicers, a new technology, maintain high optical efficiency, and MUSE is using the largest image slicers ever used in astronomy. Each spectrograph is equipped with 4000 x 4000 pixel detectors — the largest detectors used at ESO so far.

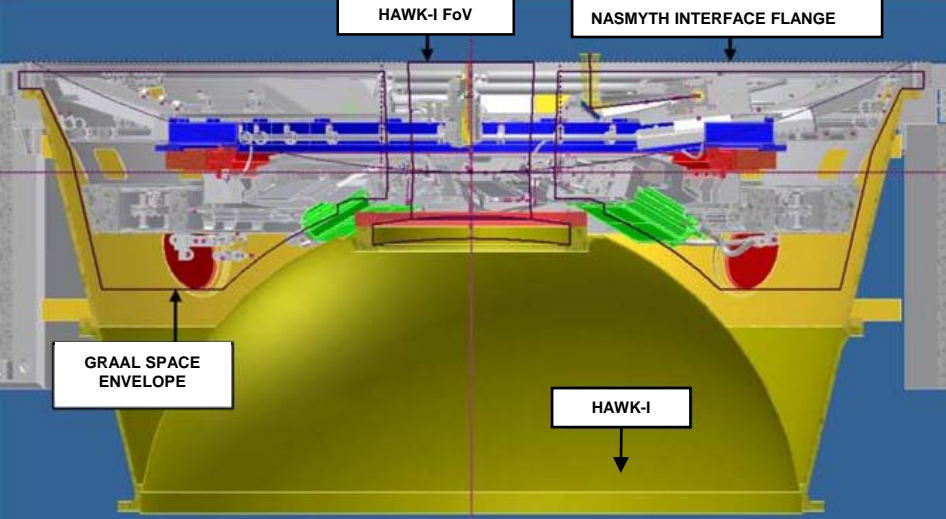

GRAAL is a seeing improver ground layer adaptive optics system, assisted by 4 LGS, with science FoV is of 7.5" square, for feeding the cryogenic NIR imager HAWK-I.

Open view of GRAAL with the HAWK-I adapter.

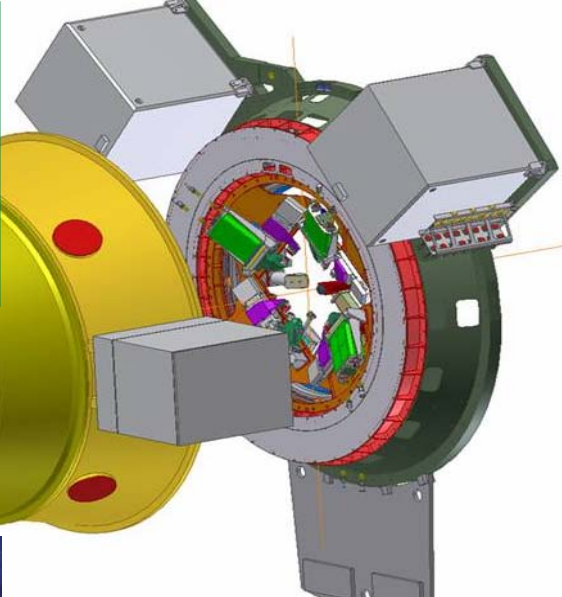

GRAAL with HAWK-I on the Nasmyth platform. Hawk-I is an already existing NIR wide field imager (7.5'x7.5' FoV).

A view cut through the median plane of the AO system shows the limited available space.

Exploded view of GRAAL mechanical structure: the bearing is designed for 150Nm friction/80kg, the torque drive for 500Nm nominal/70kg. The cable-guide system weight is 110 kg, the aluminium structure 75 kg and the steel structure 50 kg. GRAAL total weight is 950 kg (about 2900 kg with HAWK-I).



GRAAL: GLAO MODULE FOR HAWK-I



GRAAL is compact: in the simulation picture of the Nasmyth platform (on the right), the volume attached to the telescope adapter-rotator remains nearly the same as before GRAAL installation. GRAAL is tinted in red and yellow, and is in its integration configuration. One electronics cabinet (not represented) lies on the Nasmyth platform, another one on the azimuth platform.

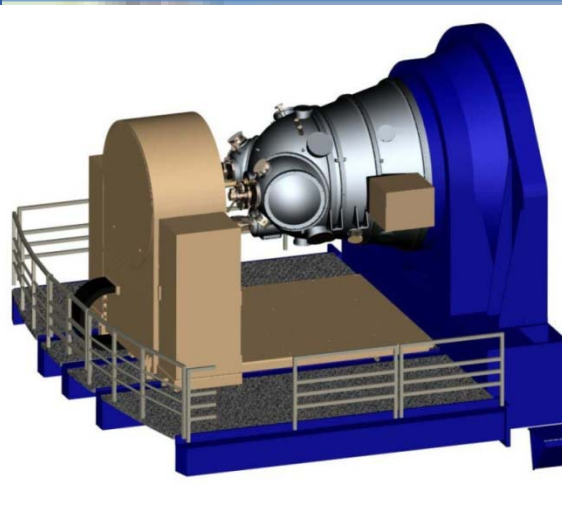

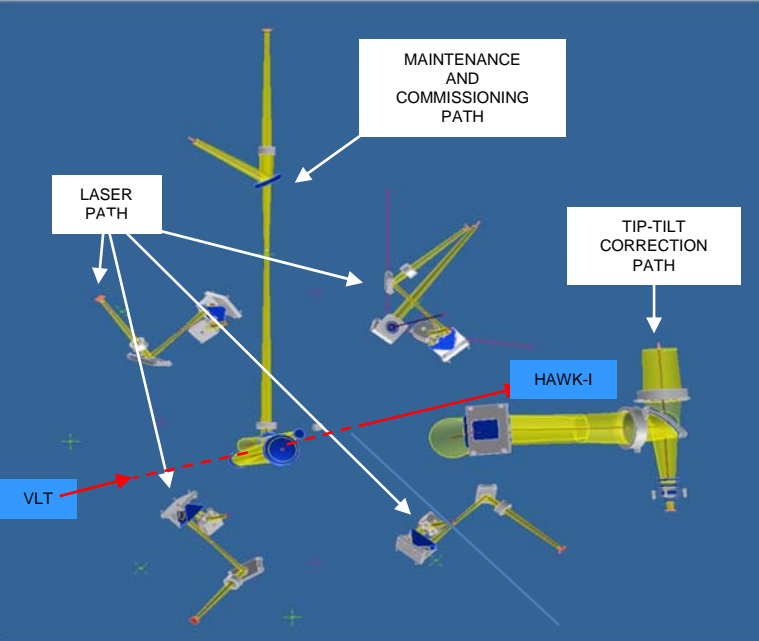

GRAAL main assembly descriptive view. The main assembly has been designed as a plug-and-play unit: no modification of any Hawk-I internal part is necessary during the installation. The design concept has been developed at ESO.

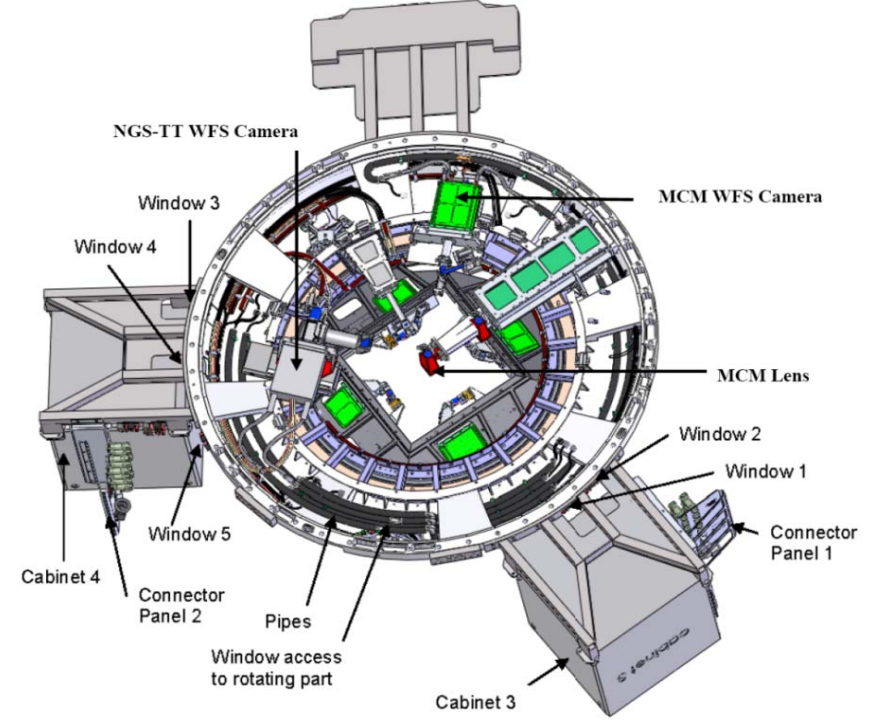

The complexity of the optical design relies in the tight arrangement of GRAAL optics in the space available between the telescope adapter and Hawk-I, requiring some optics to be located in a complex 3-D geometry. SESO started the manufacturing of the optics in June '09.

GRAAL DESIGN AND PERFORMANCES

Field of view	7.5' (10" MCM)
instrument	Hawk-I (IR imager)
modes	GLAO, SCAO
Performance GLAO	x1.7 (central pixel), 95% sky coverage
Performance SCAO	(80% in K-band)
WFS	4 LGS L3-CCD (1 e ⁻ Read out Noise) 1 TT L3-CCD 1 NGS L3-CCD
Loop frequency	≥ 700 Hz
SPARTA	HW=GALACSI
4LGSF	4 stars Ø12'/-
ASSIST	Limited FoV
Status	Detailed design, sub-contracted main assembly

GRAAL is expected to provide about a factor 2 of improvement in the occurrence of good images (<0.4"). Seeing reducer at 60% occurrence is a factor 0.8 (in K-band). Improvement is expected for all seeing conditions

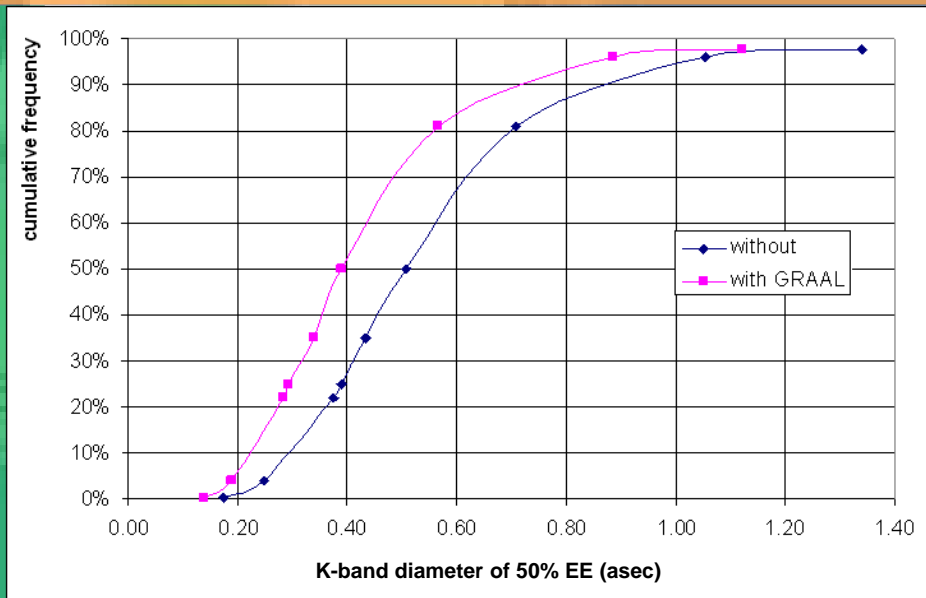



Above and below: tests of the optics at SESO



Below: one of the LGS pick-up arm mounted on its Physik-Instrumente translator, installed inside the GRAAL rotating flange at NTE..

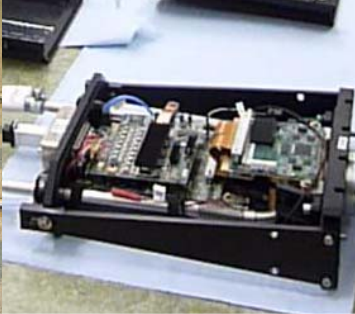

Left: WFS assembling
Left:
cooling system;
right with
electronics.

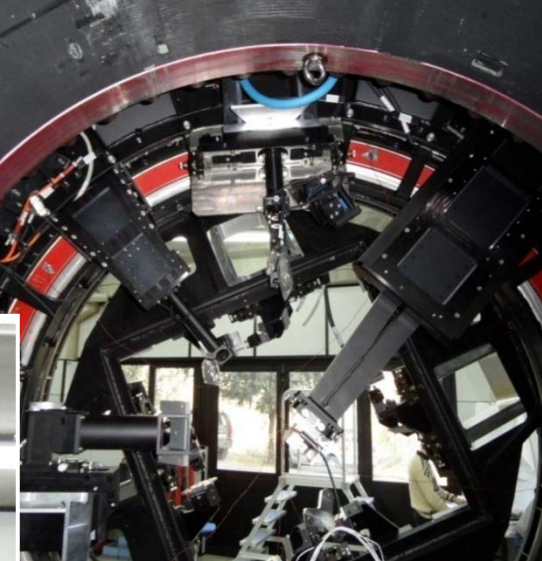

Above: from bottom left, clockwise:
TT unit, LGS calibration assembly,
MCM lens (February 2011).

Below: during assembly of the the rotating
frame at NTE (September 2010)

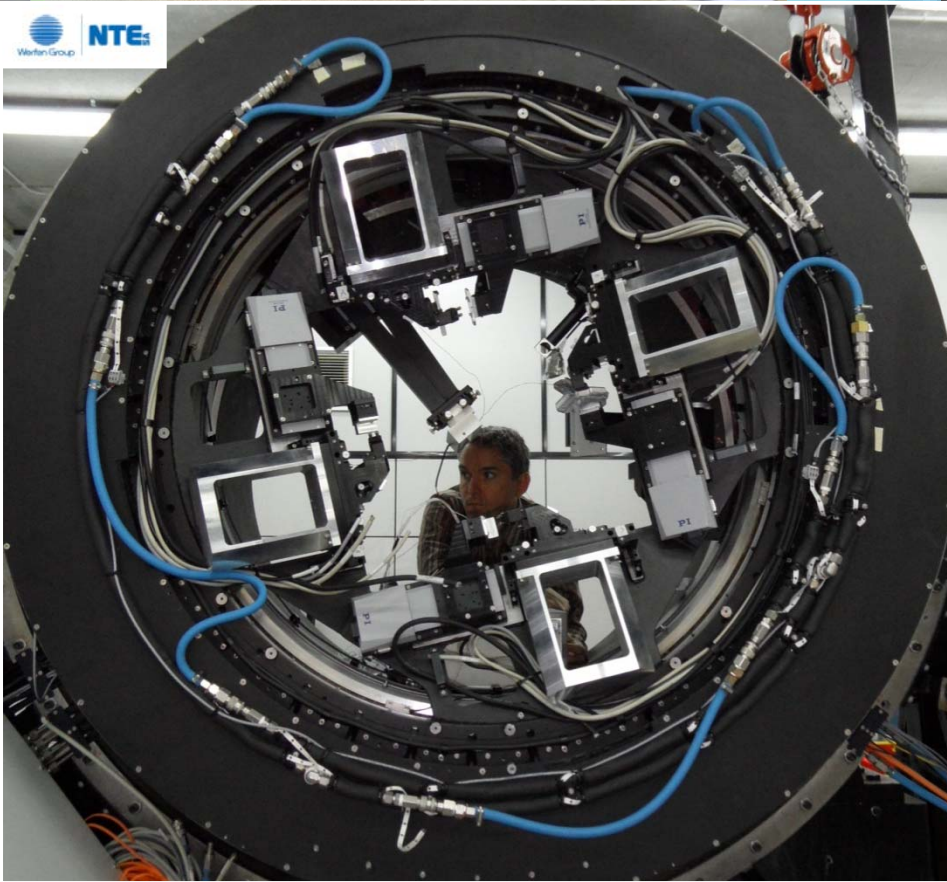

GRAAL FINAL TESTS ...

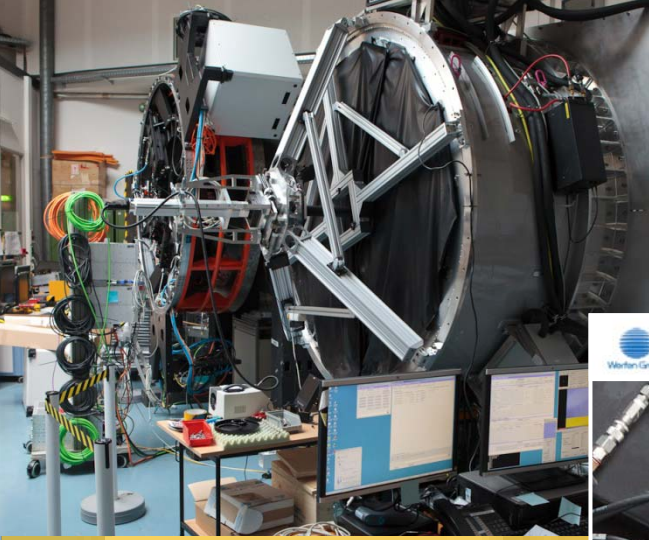

GRAAL mechanical structure has been assembled in the ESO-Garching integration hall in June 2011. The mechanics is already mounted and working, and optics are ready for integration. GRAAL will be the first instrument to be tested on ASSIST. GRAAL tests at ESO will last until end of 2012.

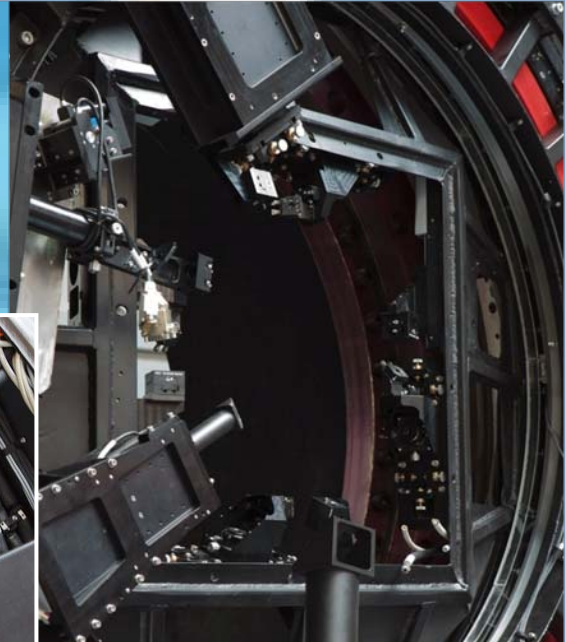

Above: enlargement of the central part of GRAAL mechanical structure, front view.

Above: GALACSI (front) and GRAAL (back) in the ESO-Garching integration hall.

Below: GRAAL mechanical structure fully integrated. The optics are missing.

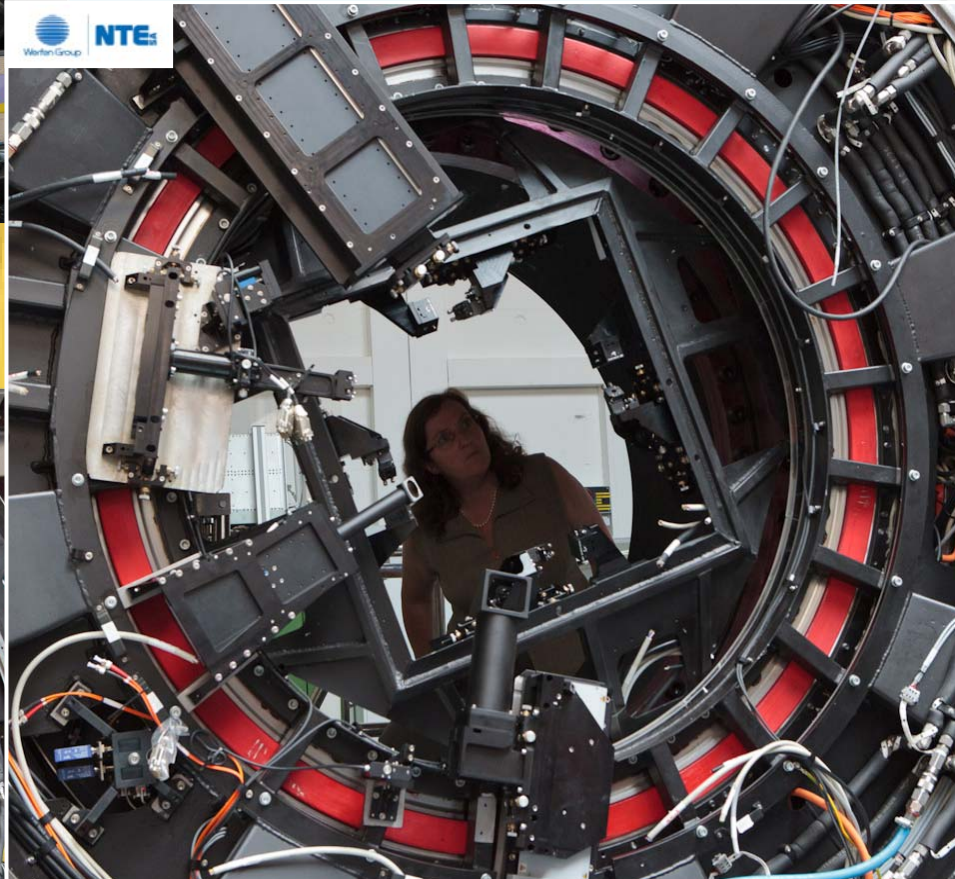

Below: the same part, view from the rear side during a special progress meeting

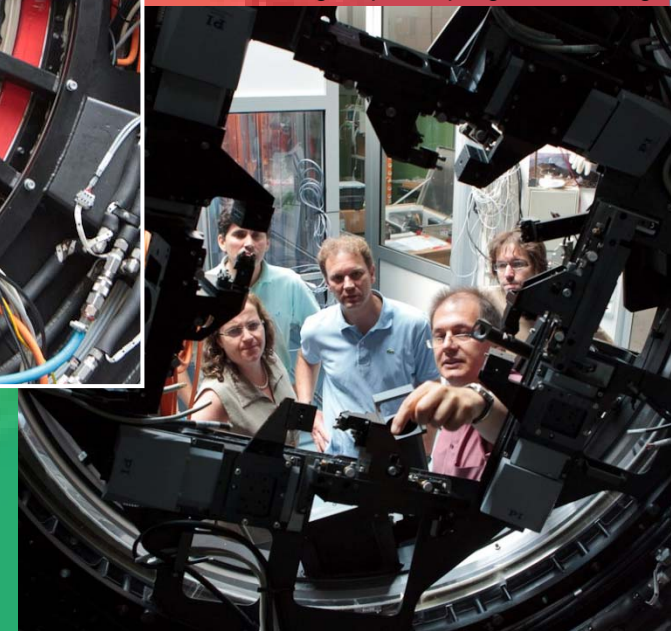
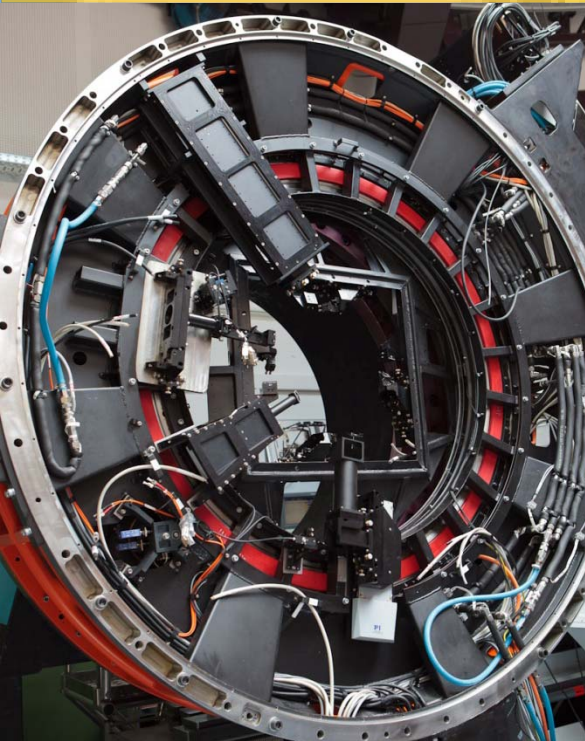

... AND NOW AT
ESO

3-D view of ASSIST assembly without the cover, with the DSM module and GALACSI separated from the adapter.

The external dimensions are about 4.5 m×4 m×3.5 m.

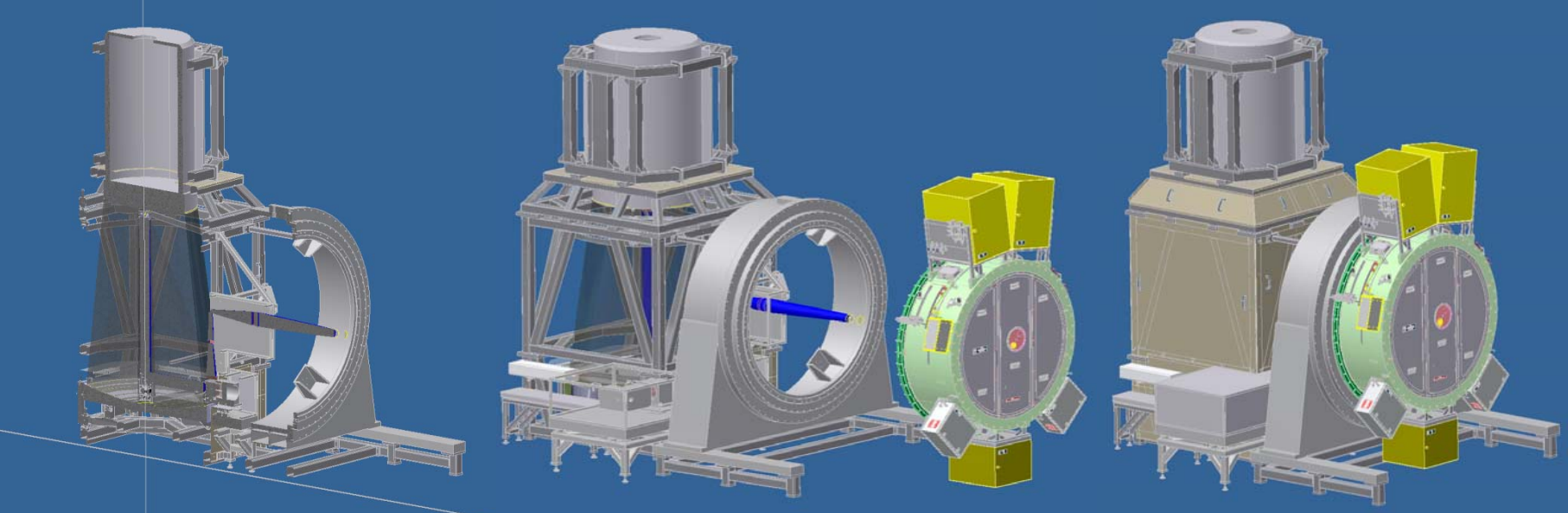

ASSIST: DSM TEST BED

ASSIST IS THE OPTICAL FACILITY DESIGNED FOR TESTING AND CHARACTERISING THE DSM, TOGETHER WITH GRAAL AND GALACSI, BEFORE INSTALLATION AT PARANAL. IT WILL BE FIRST INSTALLED AT GARCHING AND THEN SENT TO PARANAL TO AID THE DSM INSTALLATION.

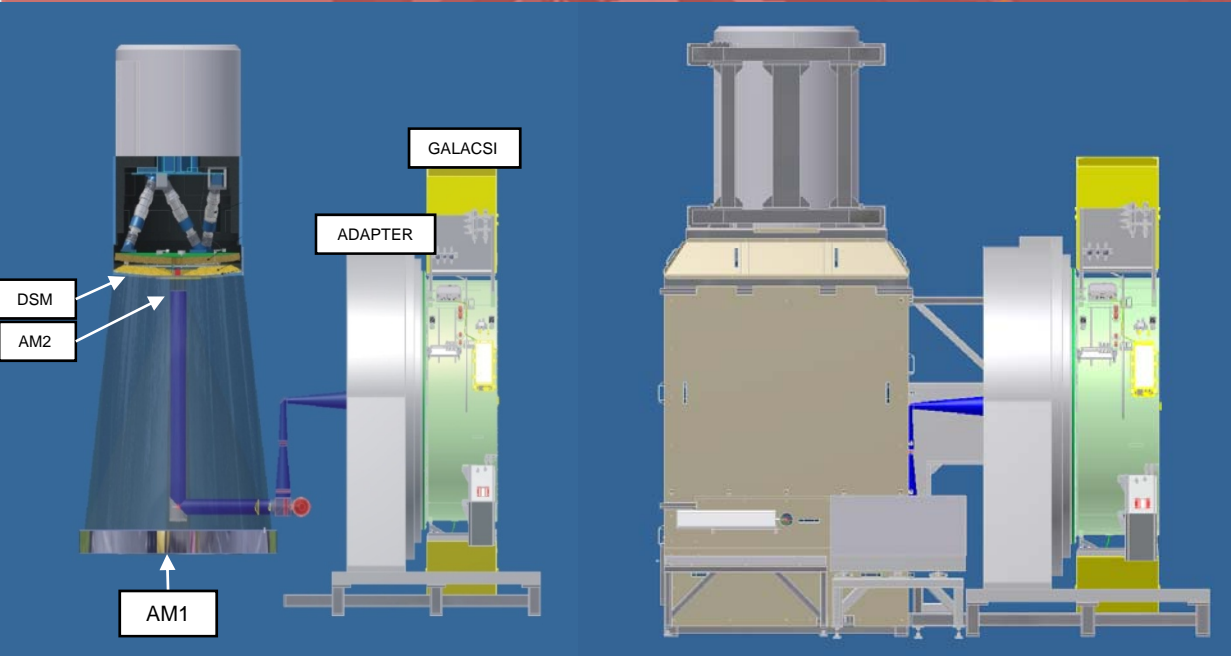

ASSIST optical design: AM1 and AM2: ASSIST mirrors; DSM: Deformable Secondary Mirror; FM: Folding mirror; SSTG: Star Simulator Turbulent Generator; VFS: VLT Focus Simulator. The NGS and LGS (GALACSI and GRAAL) sources are simulated by the Source Injection module.

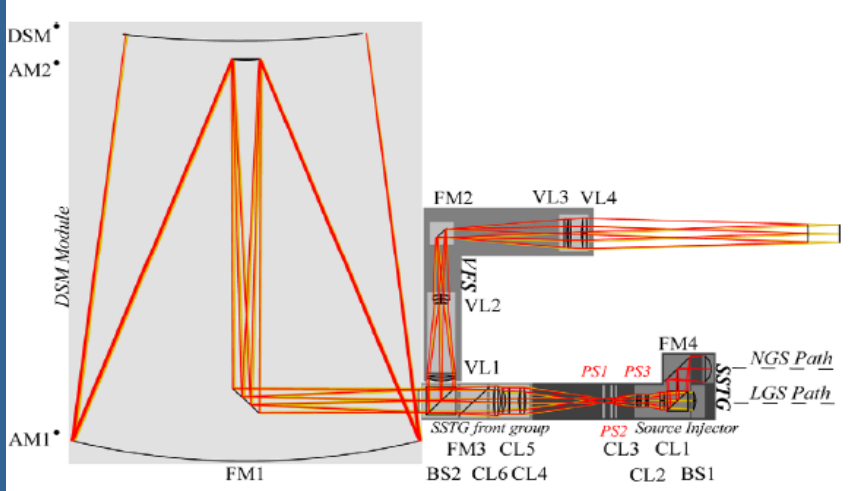



AM1 spherical polishing started at end of September 2009. Left: carefully checking the mirror after final aspherical polishing at AMOS (February 2011).



Above: microscopic measurement of the roughness. Right: the final testing of AM1 surface implies a complex interferometric setup including a Computer Generated Hologram mask for taking care of its aspherical shape.

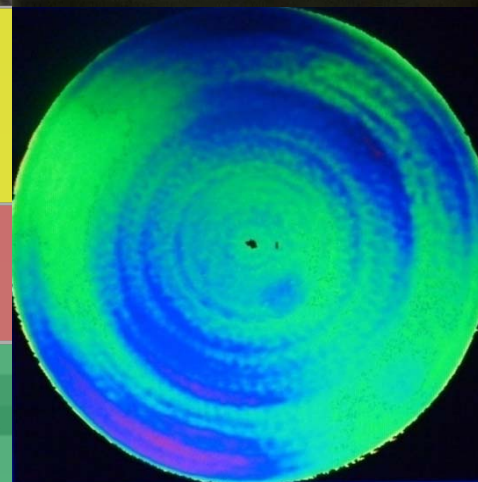
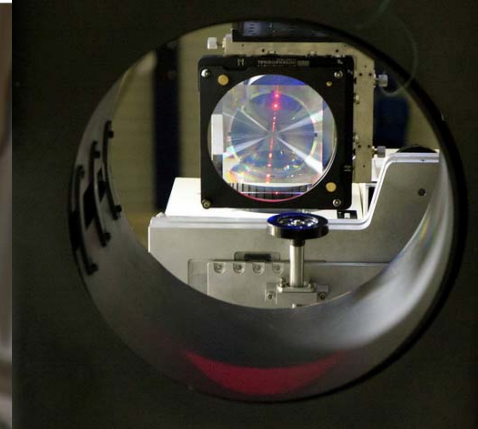

ASSIST AM1 PRIMARY MIRROR



The final specifications on the whole AM1 surface are less than 300 nm RMS on the whole useful diameter (1650 mm), up to less than 10 nm RMS for spatial scales smaller than 100 mm.

AM1, an aspherical $f/1$ mirror, with 1.7 m diameter, made of Zerodur, is the most critical component of ASSIST.

On the left: AM1 is in the coating chamber at Calar Alto Observatory (April 2011), after final protected aluminum coating.

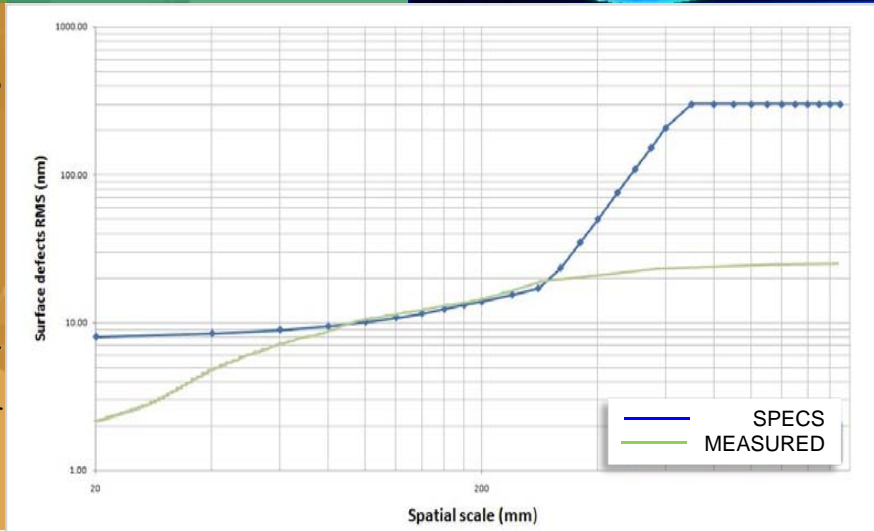

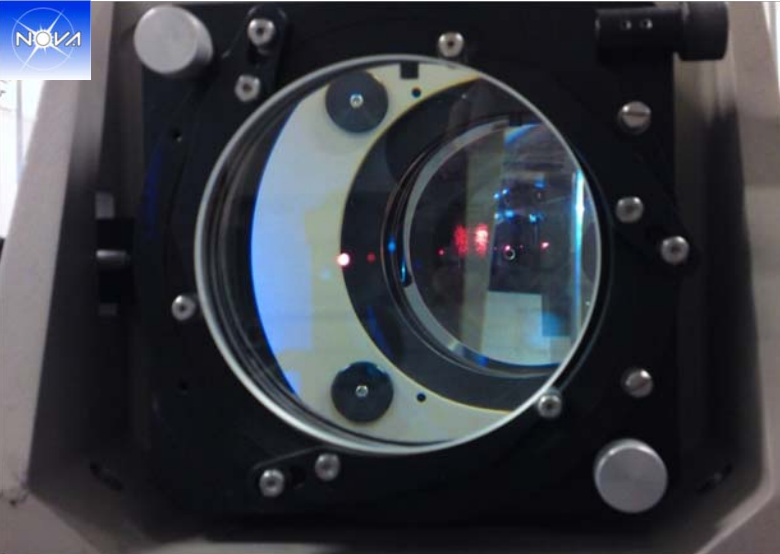

Left: AM2 polishing and testing at NOVA optical laboratory at ASTRON (June 2010): AM2 is an aspherical, 140 mm diameter mirror, which surface quality is very critical for allowing GRAAL and GALACSI testing with ASSIST.



Above: full assembling of the ASSIST main structure mechanics at Boseenkool (NL) (February 2011). Left: the tower before enclosure. Right: with enclosure. On top of the tower the dummy loads simulating the DSM weight are visible.

Winlight System

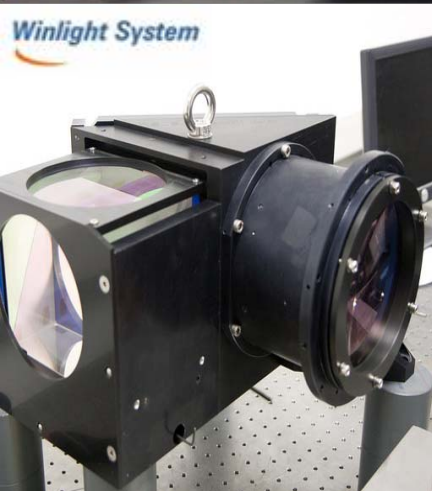

Right: the LGS sources of ASSIST.



Left: the external modules during final testing at Winlight: clockwise, from upper left: the frong group, FM4, the source group, VL12.

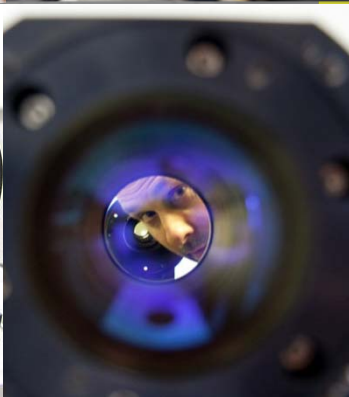
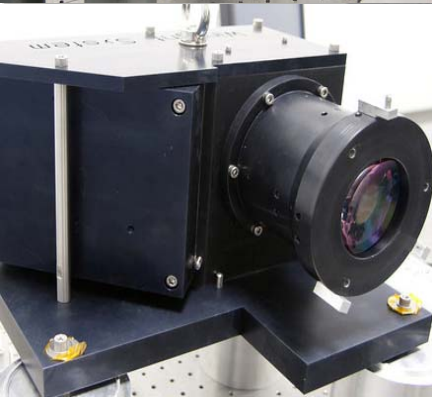

Right: one of the first Phase Screens produced by SILIOS: the phase map is visible in transparence on the glass.



ASSIST MANUFACTURING

Below: the frame allowing Phase Screen exchange and rotation. This is part of the Star Simulator and Turbulence Generator module (SSTG). The Phase Screens allow to simulate a seeing and turbulence profile including coherence.



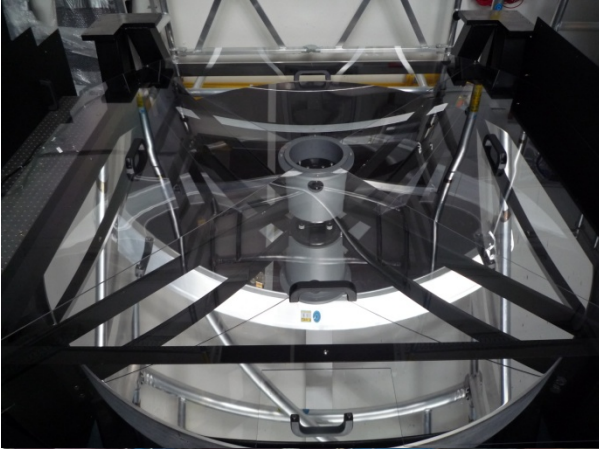

AM1 in its cell and FM1 spider

Right: alignment of the optics with the site telescope



Right: AM2 in its spider

Center right: internal view from the top

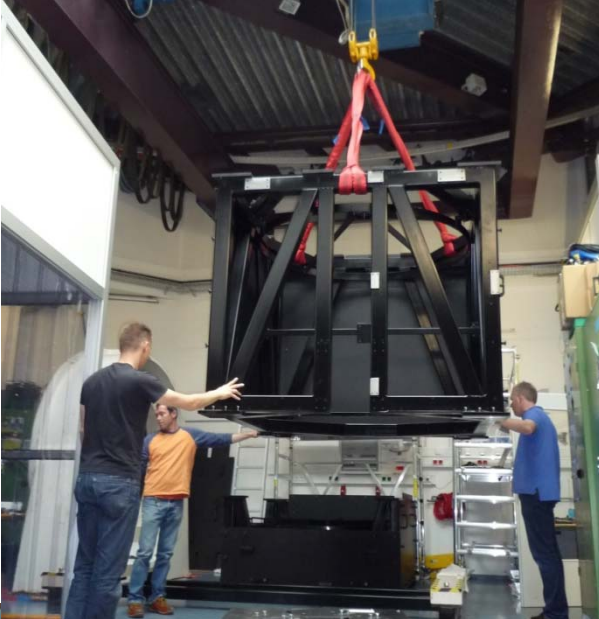

Left: mechanical structure assembling

Right: the whole structure assembled (June 2011): DSM tower, Shack-Hartmann tower and adaptor ring. The total height is more than 5 m.



Left: 400 kg AM1 handling



ASSIST INTEGRATION AT ESO

Right: centered reflected rings from AM2

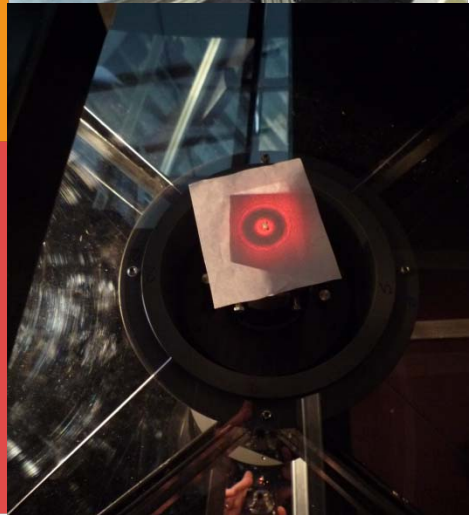

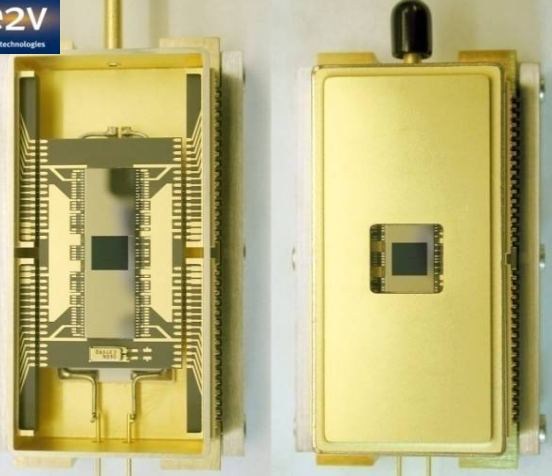

CCD 220:
240x240
pixels,
standard
silicon
8 EM
amplified
outputs up to
15 Mpix/sec,
1400
frames/sec.

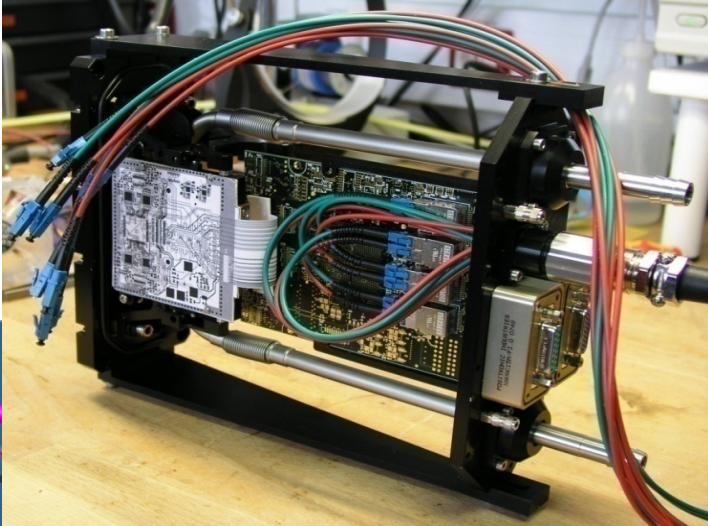
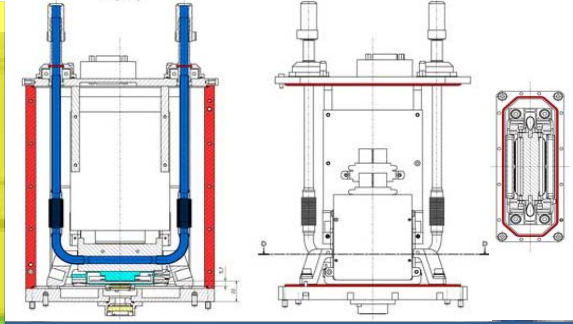

WFS camera with OCAM clock board, Hermetic connectors (power entry, Peltier control, temperature sensing, alarms), Fiber interface (4 duplex links, 3.125 Gb/s per link = 12 Gb/s, Connection to NGC back-end, Connection to RTC), cooling system prototype (pressure level of 20 bar)

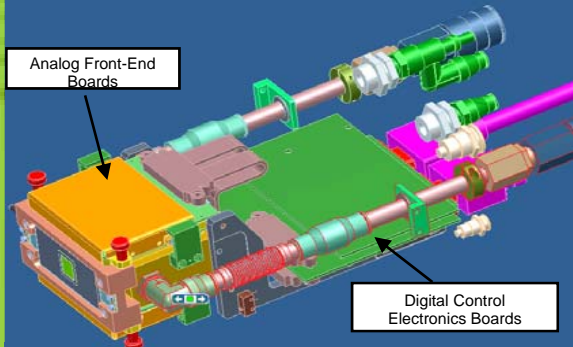

The WFS camera is very compact
168x240x75 mm. Weight: 3.5kg

CCD 220 thermal model with heat sink design: cryogenic tests are satisfactory (up to required -45°C). Water pipes used for cooling are located on two opposite sides of the heat sink. Heat sink is meshed here in dark blue, water is meshed in blue.

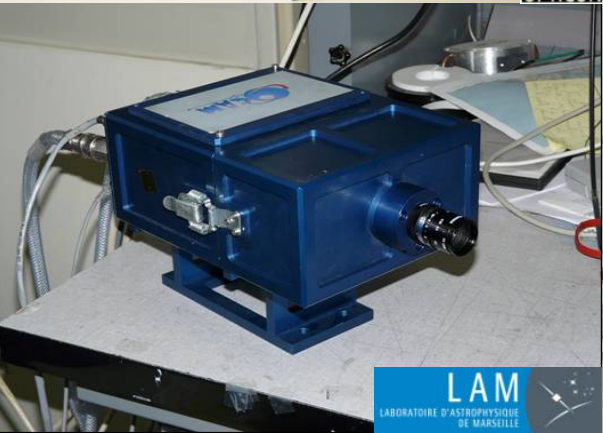

OCam Test
Camera
part of
Opticon
JRA2 FP6
technology
transfer
expected
soon
duplications
for ESO and
Grantecan.

WFS DETECTORS and ELECTRONICS

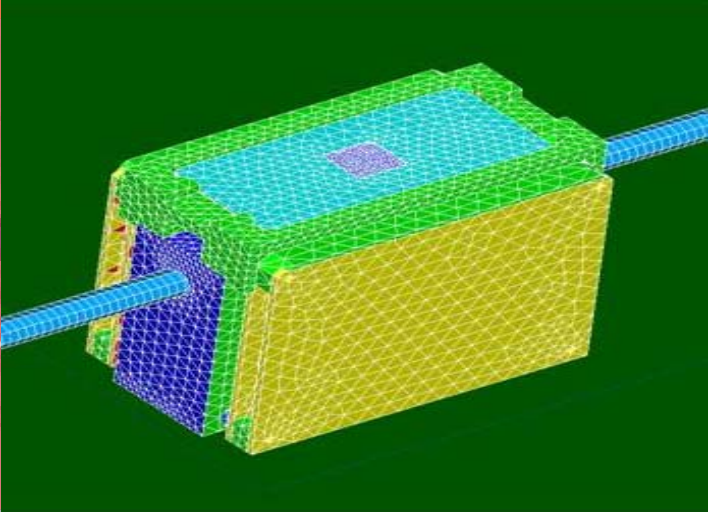

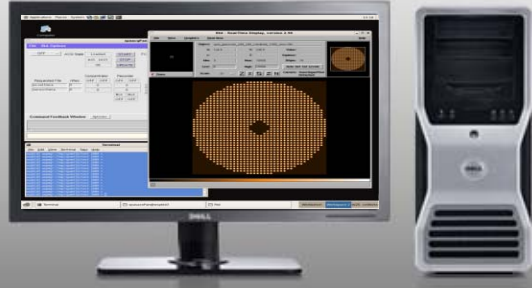

User and Engineering Interface
 Real Time Data Display
 Standard hardware
 Rich test tool suite
 Full VLT SW compatible via gateways



High End Intel CPU / Multi-core / Multi-CPU, Linux based
 Industry standard libraries and middleware, commercial (40kE) and open source (CORBA/DDS)
 Modular, scalable, fully reusable

SUPERVISOR

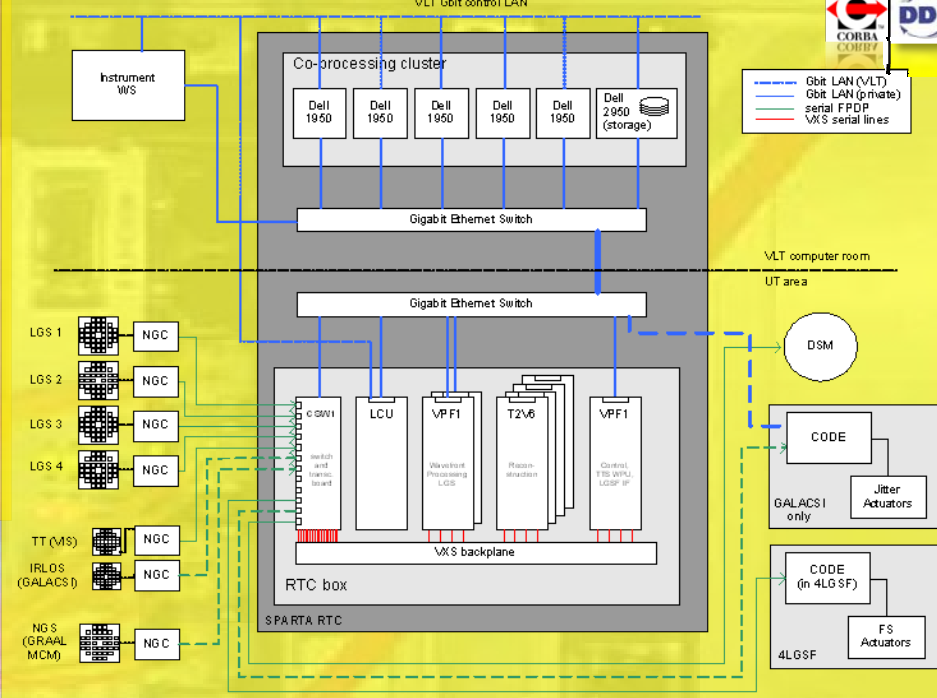

SPARTA

Standard Platform for Adaptive optics Real Time Applications

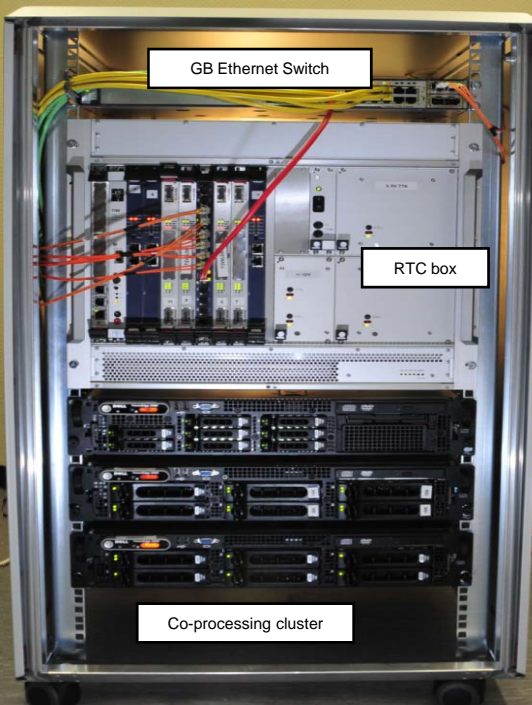

RTC box (~200k€/system):
 hard real-time system to drive the AO control loops; can receive data from multiple sensors (4+1 for AOF) and can control multiple mirrors (1+4 for AOF) at high speed (1 KHz for AOF) with extremely low jitter and very low latency. Fully software reconfigurable to support multiple applications (GRAAL HAWK-I and GCM). High-tech crate, fully EMI tested, active protection.

Supervisor (~20k€/system):
 High-throughput, high-performance, parallel soft real-time system. Controls the real-time box, implements the AO "business logic", handles computational intensive tasks like performance estimation, loop optimization, atmospheric statistics, calibration.

SPARTA is a highly scalable hardware and software platform for adaptive optics real-time computers providing very low latency together with high throughput. All 2nd generation AO instruments (including GRAAL and GALACSI) will be equipped with a SPARTA RTC system.

REAL-TIME BOX



Multi-technology Real-Time Box: DSP + FPGA + CPU
 Very low total latency (<200us) with FPGAs managing real time communication
 DSPs for floating point operations, CPUs for monitoring and idle-time control.
 Modular, upgradeable, scalable, object oriented, all built with COTS components
 High Performance WPU (60kE, <1us latency), parallel reconstructor
 Serial I/O, long range fibre interface, 2.5 Gb/s (sFPDP)

MILESTONES

	CDR	PDR	FDR		ARR	FAT	PAE	PAC
ASSIST	Sept.'05 KO Feb.'06	Oct.07	30.06.09		2Q11	3Q11	2Q12	4Q14
DSM			18.12.07		24.09.09	Apr.'11	4Q12	
GRAAL		Mar.07	10.03.09		2Q11	4Q12	2Q13	
GALACSI		Feb.08	10.02.09	16.06.09	2Q11	2Q13	4Q13	
4LGSF		30.09.09	3.02.11		2Q11	N/A	2Q13	
AOF Sys.		24.04.08	29.04.10		N/A	4Q11 (TRR)	4Q13	
UT4 Upg.	29.04.10	N/A	2Q11		N/A	N/A	1Q12 Phasel	3Q12 PhaselI
<i>MUSE</i>			Dec.07	Mar.09	N/A		2Q12	(2Q13)
<i>SPARTA</i>		Jun.07	Sept. 08		N/A	2Q11 (SPHERE)	4Q13 (GALACSI)	N/A

ORGANIZATION CHART

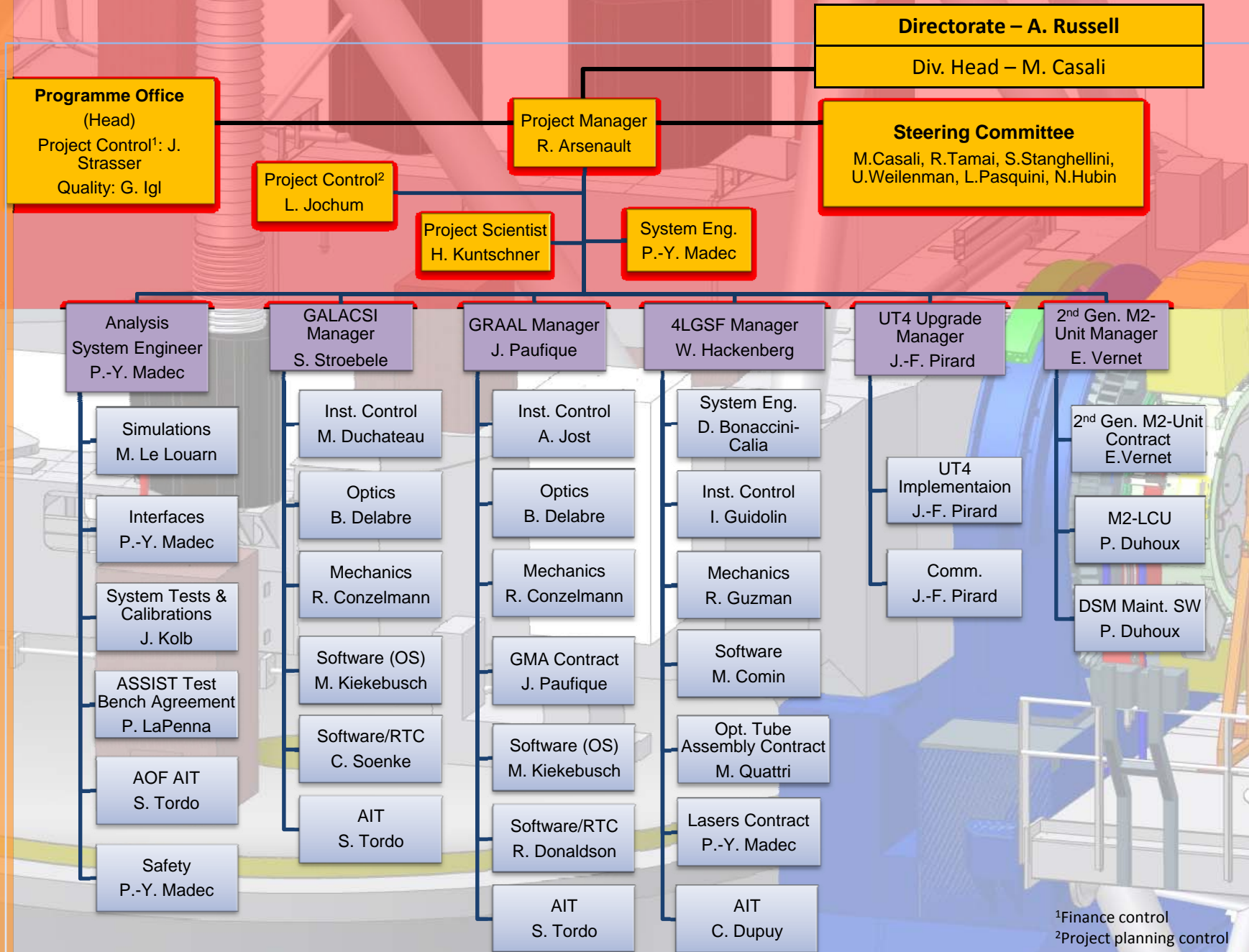

¹Finance control
²Project planning control



Optical Infrared Coordination Network for Astronomy
<http://www.astro-opticon.org/>



Nederlandse Organisatie voor Toegepast Natuurwetenschappelijk Onderzoek
<http://www.tno.nl/>



Nederlandse Onderzoekschool voor de Astronomie
<http://www.strw.leidenuniv.nl/nova/>



Istituto Nazionale di Astrofisica
<http://www.inaf.it/>



Sterrewacht Leiden
<http://www.strw.leidenuniv.nl/>



Advanced Mechanical and Optical Systems
<http://www.amos.be/>



Laboratoire d'Astrophysique de Marseille
<http://www.oamp.fr/infogluceDeliverLive/www/+LAM>



FASORtronics
http://www.fasortronics.com/FASORtronics/FASORtronics_LLC.html



Société Européenne de Systèmes Optiques
<http://www.seso.com/uk/>



Sagem
<http://sagem-ds.com/>



MUSE consortium
<http://muse.univ-lyon1.fr/http://sagem-ds.com/>



Hextec
<http://www.hextek.com/>

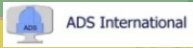

ADS International
<http://www.ads-int.com/>



Microgate Engineering
<http://www.microgate.it/engineering/default.asp>



Schott
<http://www.schott.com/>



Winlight Optical System
<http://www.winlight-system.com/>



SILIOS Technologies
<http://www.silios.com/>



Array Electronics
<http://www.array-electronics.com/>



e2v
<http://www.e2v.com/>



NTE
<http://www.nte.es/>



Toptica Photonics
<http://www.toptica.com/>



MPB Communications Inc.
<http://www.mpbc.ca/>



ESO
 European Organisation
 for Astronomical
 Research in the
 Southern Hemisphere

AOF Industrial Contractors & Partners



Calar Alto Observatory
<http://www.caha.es/>



Machinenfabrik Boessenkoo bv
<http://www.boessenkool.com/>



JDSU
<http://www.jdsu.com/en-us/Pages/Home.aspx>



Precision Optics Gera
http://www.pog.eu/en/products_os_00.html



SUSS MicroTec
<http://www.suss.com/>



mso jena Mikroschichtoptik GmbH
<http://www.suss.com/>



Physik Instrumente Piezo nano positioning
<http://www.physikinstrumente.de/de/index.php>



ESO
European Organisation
for Astronomical
Research in the
Southern Hemisphere

P. Amico, R. Arsenault, D. Bonaccini-Calia, B. Buzzoni, M. Comin, R. Conzelmann, B. Delabre, R. Donaldson, M. Duchateau, P. Duhoux, C. Dupuy, E. Fedrigo, I. Guidolin, R. Guzman Collazos, W. Hackenberg, G. Hess, N. Hubin, L. Jochum, P. Jolley, A. Jost, P. Jolley, L. Kern, M. Kiekebusch, J. Kolb, H. Kuntschner, P. La Penna, M. Le Louarn, J.-L. Lizon, P.-Y. Madec, A. Manescau, J. Paufique, J.-F. Pirard, M. Quattri, J. Quentin, C. Soenke, S. Stroebele, S. Tordo, E. Vernet

Preparation & Editing: P. La Penna, ESO